

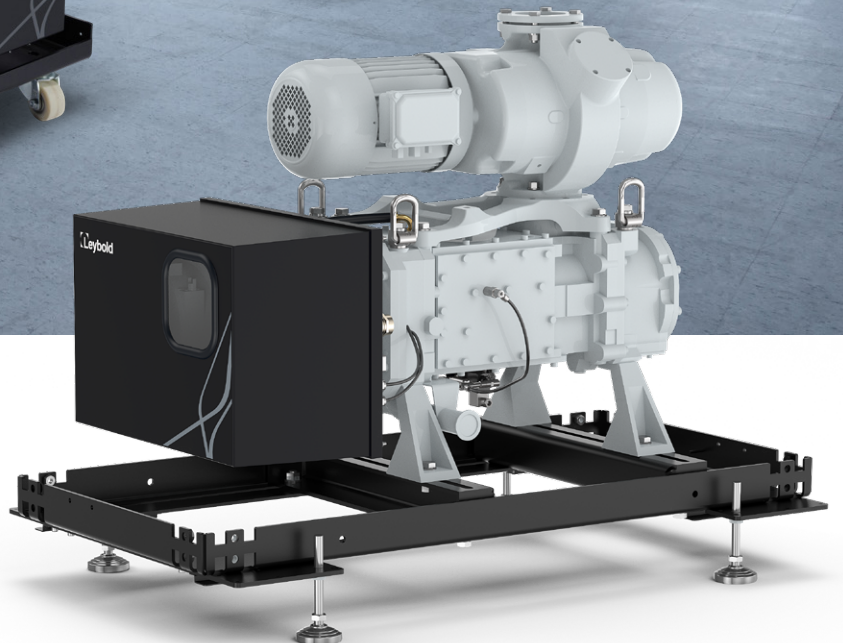

DRYVAC Systems

Powered by Efficiency



Dry Compressing Pump Systems

Leybold has refined its DRYVAC vacuum pump systems, making them adaptable for a variety of applications — The recipe is simple and efficient: Take a dry compressing screw vacuum pump and a roots pump, combine both of the proven technologies along with pressure measurement, shut-off devices and electrical control, creating a turn-key smart vacuum system that is cost-effective and completely ready for use by the customer.

Since 2011 the fore vacuum systems of the DRYVAC pump series by Leybold are already

being used successfully in various processes, which can be simple or very challenging. The pumping systems are known for their maximum suction capacity while operating at minimum operating costs.

Now, Leybold has developed the systems further: The two-stage DRYVAC systems distinguish themselves particularly by their modular design and the resulting improved user friendliness and easy servicing. All equipment features are aligned to the requirements of the different markets.



- ✓ **Leybold has refined its DRYVAC vacuum pump systems, making them adaptable for a variety of applications**
- ✓ **Basic and Smart System Configuration**

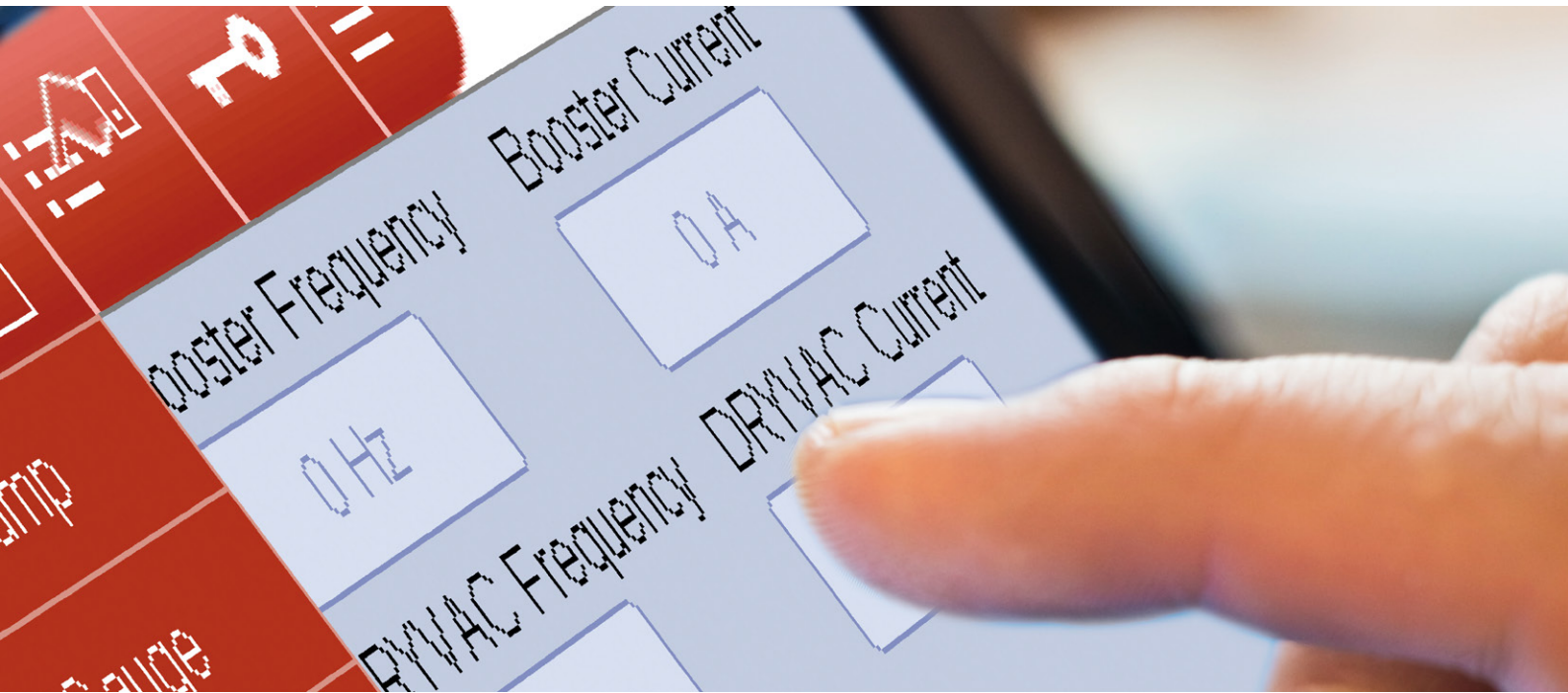

GENERAL ADVANTAGES

- Extremely compact design provides more space in production areas
- Very low noise level improves working environment conditions
- Significant cost reduction because of high energy efficiency
- Clean technology with no oil emissions
- Optimized for fast cycle / load lock applications

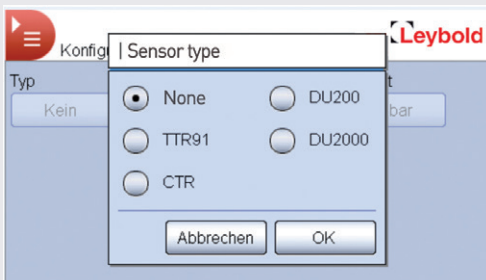

SPECIAL FEATURES AT A GLANCE

- Direct connection of measuring gauges
- Intelligent Version: Integrated operating and monitoring electronics
- Improved lead times due to modularization
- Easier tool integration by standard interfaces

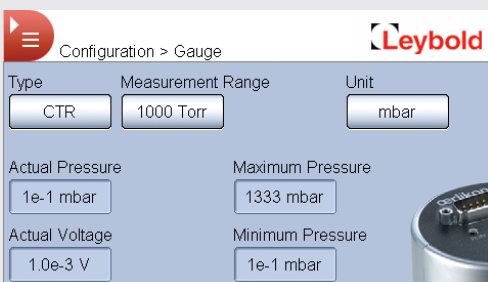

A PLUS IN ENERGY EFFICIENCY

The high energy efficiency is met by the customized frequency converter. This leads to overall low power consumption. The average energy consumption of the DRYVAC system is about 30 percent lower than for competitive products in the market.



DRYVAC SYSTEMS are available either as Basic or Smart system configuration.



*DV 200, DV 300, DV 500 are available as Basic only.
Please contact Systems & Solutions for intelligent versions.

BASIC

Pre-assembled vacuum pump systems (basic version). Monitoring, control, programming, and power electronic components to be provided by the customer.

STANDARD CONFIGURATION:

- Exhaust to the side
- Triple purge gas module
- DV 200, DV 300, DV 500 available with shaft seal and gas ballast purge only*

OPTIONAL CONFIGURATIONS:

Double purge gas module, gas ballast system, non-return valve, quick-access couplings (water), mating connector for power & signal supply, relay board (digital I/O)

ADVANTAGES:

- High performance with excellent cost-performance ratio
- Worldwide service & spare parts availability
- Rapid response times

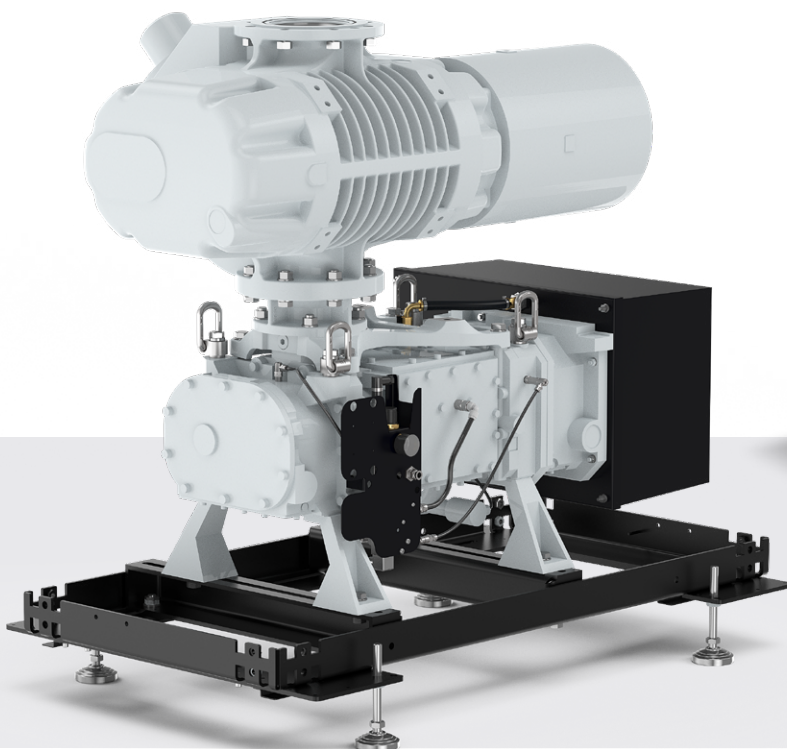



SMART

The smart pump system versions are characterized by integrated power electronics, monitoring devices for the purge gas system and key parameters, easy and user-friendly operation handling (local / remote), and additional features, e.g. connecting a gauge head.

STANDARD CONFIGURATION:

- Digital I/O interface
- Prepared for connecting a variety of different gauge heads (CTR, DU, TTR)
- Emergency Stop (EMS)
- Compensation for voltage drops ($\leq 2s$)
- Triple purge gas module
- Exhaust to the side

OPTIONAL CONFIGURATIONS:

Double purge gas module, gas ballast system, non-return valve, quick-action couplings, Profibus, Ethernet or Profinet interfaces!

ADVANTAGES:

- High performance at attractive prices
- Autonomous vacuum pump system
- Worldwide service & spare parts availability
- Rapid response times



DRYVAC SYSTEMS are robust, reliable and durable for high process requirements.

APPLICATIONS:

- Furnace
- Battery
- Crsytal Pulling
- Glass Coating
- Display
- Freeze Drying
- Solar
- Protective Coating
- Sputtering / Decorative Layers



BASIC



BASIC



RELIABILITY:

- Platform based product design proven in a huge installed base
- Tolerance to misuse

RANGE OF VACUUM:

- Pumping speed from 500 m³/h up to 9,800 m³/h
- Integrated smart monitoring of major parameter (only DS)
- Standard Digital I/O interface and Profibus (optional) for the whole product family (only DS)

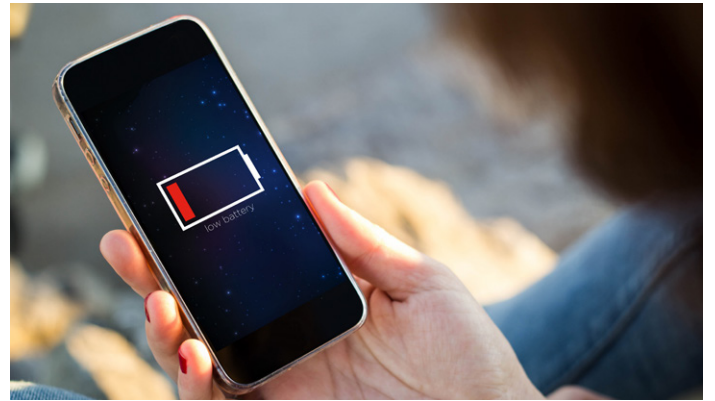

PERFORMANCE:

- Fast pump down times –by high throughput pump mechanisms
- High pumping speed for dry and booster pumps

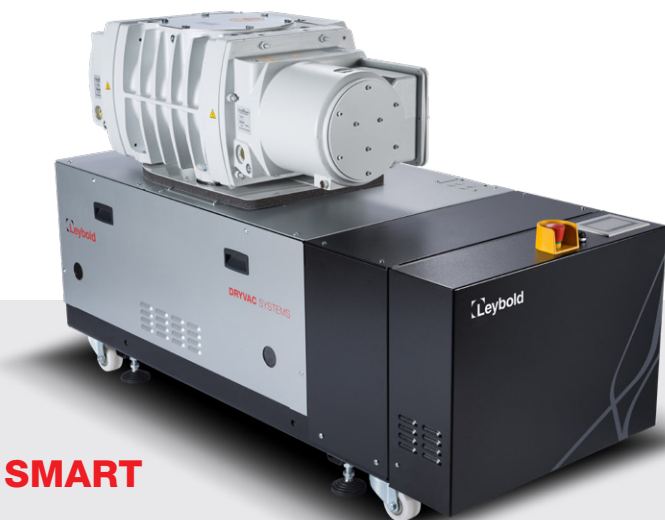

SMART



Technical Data

BASIC

		Roots Blower		Fore Vacuum Pump	
		WSU 501	WH 700 FC	WSU 1001	WSU 2001
		DV 200/DV 300	DV 200/DV 300	DV 200/DV 300	DV 200/DV 300
Max effective pumping speed	m³/h	505 (50 Hz) 606 (60 Hz)	710 (50 Hz) 860 (60 Hz)	1000 (50 Hz) 1200 (60 Hz)	2050 (50 Hz) 2460 (60 Hz)
Power at ultimate pressure	kW	4.8 (50 Hz) 4.8 (60 Hz)	4.3 (50 Hz) 4.4 (60 Hz)	5.1 (50 Hz) 5.2 (60 Hz)	5.6 (50 Hz) 5.9 (60 Hz)
Water	l/min	8	9	8	
Inlet	DN	63 ISO-K	100 ISO-K		160 ISO-K
Outlet		40 ISO-KF			
Dimension (L x W x H)	mm	on request			
Noise Level (@ pend)	dB(A)	66			69
Product Number (DV 200)		505058V001	505059V002	505060V001	505061V001
Product Number (DV 300)		505062V001	505063V002	505064V001	505065V001

		Roots Blower		Fore Vacuum Pump					
		WSU 1001	WSU 2001	WH 2500	WH 4400	WH 2500	WH 4400	WH 7000	
		DV 500	DV 500	DV 500	DV 500	DV 800	DV 800	DV 800	
Max effective pumping speed	m³/h	1000 (50 Hz) 1200 (60 Hz)	2050 (50 Hz) 2460 (60 Hz)	2500 (50 Hz) 3000 (60 Hz)	4400 (50 Hz) 5280 (60 Hz)	2200 (50 Hz) 2600 (60 Hz)	3700 (50 Hz) 4300 (60 Hz)	5400 (50 Hz) 6250 (60 Hz)	
Power at ultimate pressure	kW	5.5 (50 Hz) 5.6 (60 Hz)	6 (50 Hz) 6.3 (60 Hz)	5.5 (50 Hz) 5.7 (60 Hz)	5.8 (50 Hz) 6 (60 Hz)	8.6 (50 Hz) 8.7 (60 Hz)	8.2 (50 Hz) 8.3 (60 Hz)	8.4 (50 Hz) 8.5 (60 Hz)	
Water	l/min	8		9	12.2	15.7	15.7		
Inlet	DN	100 ISO-K	160 ISO-K	250 ISO-K			320 ISO-K		
Outlet		63 ISO-K							
Dimension (L x W x H)	mm	on request				1349 x700 x 1074			
Noise Level (@ pend)	dB(A)	66	69	67		70			
Product Number		505121V001	505122V001	505123V001	505124V001	DS6301b0000	DS6201b0000	DS6101b0000	

These are examples. For further details please contact our Systems + Solution Team.

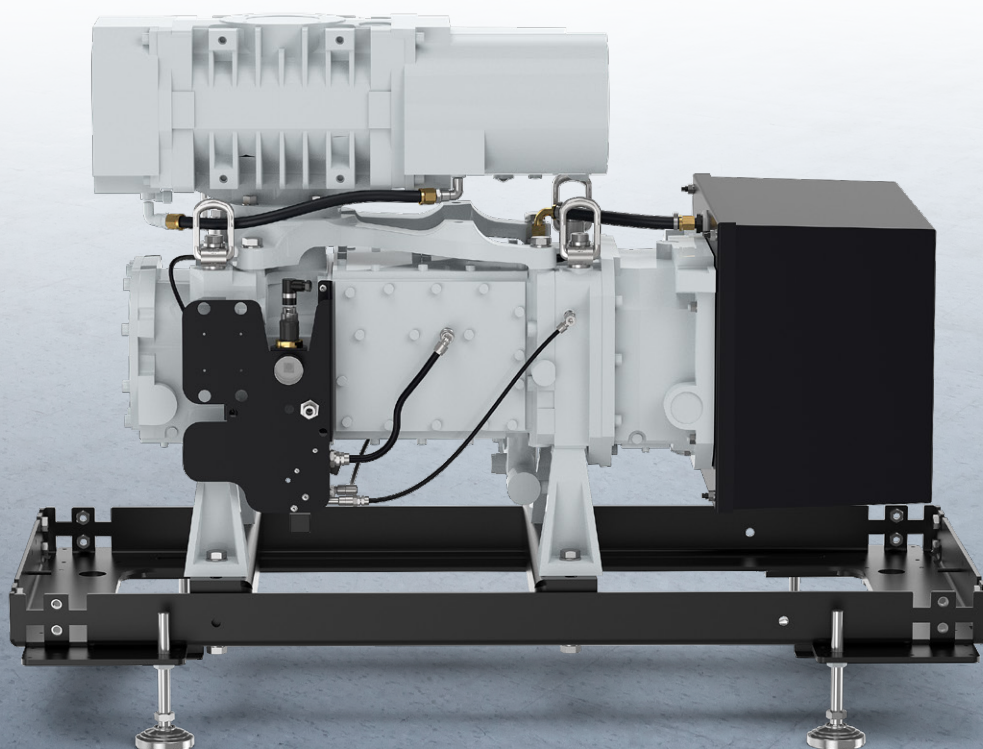

SMART

		Roots Blower		Fore Vacuum Pump	
		WSU 2100	WHU 2500	WH 2500	
		DV 650		DV 650	
Max effective pumping speed	m³/h	1750 (50 Hz) 2050 (60 Hz)	2150 (50 Hz) 2500 (60 Hz)	3750 (50/60 Hz)	
Power at ultimate pressure	kW	7.8 (50 Hz) 8.0 (60 Hz)	7.8 (50 Hz) 7.9 (60 Hz)	8.4 (50/60 Hz)	
Water	l/min	6		9.7	
Inlet	DN	160 ISO-K		250 ISO-K	
Outlet		63 ISO-K			
Dimension (L x W x H)	mm	1532 x 666 x 1124		1532 x 666 x 984	
Noice Level (@ pend)	dB(A)	<80		<65	
Product Number		DS1411iT00000		DS1303iT00000	

		Roots Blower		Fore Vacuum Pump	
		WHU 4400	WH 4400	WH 7000	
		DV 650		DV 650	
Max effective pumping speed	m³/h	3600 (50 Hz) 4200 (60 Hz)	5150 (50/60 Hz)	6800 (50/60 Hz)	
Power at ultimate pressure	kW	8.1 (50 Hz) 8.3 (60 Hz)	8.9 (50/60 Hz)	8.9 (50/60 Hz)	
Water	l/min	13.2			
Inlet	DN	250 ISO-K		320 ISO-K	
Outlet		63 ISO-K			
Dimension (L x W x H)	mm	1532 x 666 x 1074		1532 x 701 x 1074	
Noice Level (@ pend)	dB(A)	<65			
Product Number		DS1212iT00000		DS2232iT00320	

Configuration matrix for ordering DRYVAC Systems

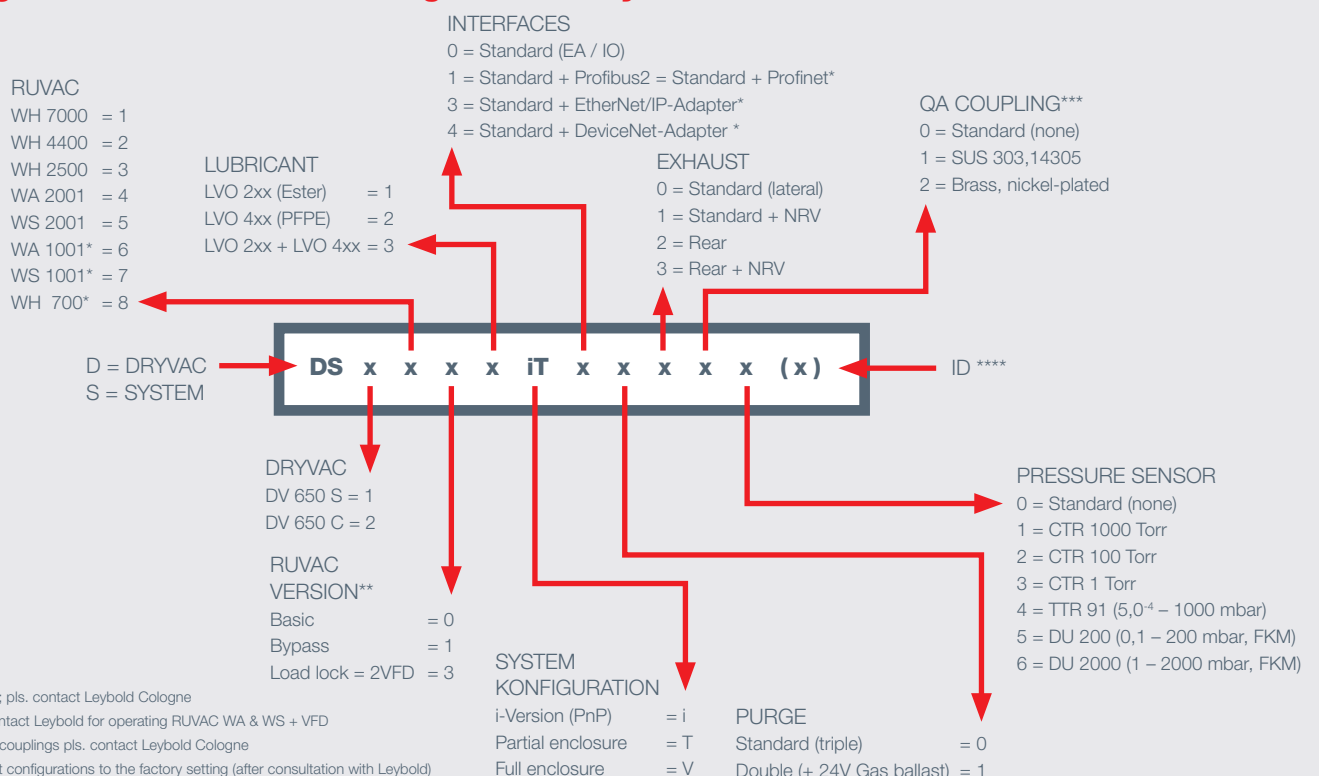

Systems + Solutions

Customer first – competence for tailor-made solutions worldwide

The Systems + Solutions business unit with its **global setup delivers tailor-made solutions** solving the customer's demands. Listening carefully to the customer the core function of our organization is to meet customer's expectations by identifying and **providing the best vacuum concept**. Our portfolio varies from standard to customized and specialized vacuum systems and Solutions. **We address a wide range of vacuum applications and markets** including integration in specific production environments.

Working in close collaboration with sales, we support integrated application development, engineering and design. Production sites in North Americas Europe and China ensure a close proximity to our customers with local assembly and test capabilities and efficient order execution. **This makes our team a true global player and undisputed market leader in the field of vacuum systems.**



Service: Easy, Competent, Reliable

We are where you are

With our comprehensive range of innovative service solutions, we offer unrivalled support for your Leybold vacuum pumps and we are committed to:

- **Providing you with a reliable, first-class service throughout your pump's lifecycle, no matter where in the world it is installed**
- **Maximizing your pump's uptime and ensuring it gets the best possible service**
- **Offering you specialist support with preventive maintenance and repairs**



Maintaining your uptime and reducing the risk of production downtime is critical. Wherever you are, Leybold is there to support you as your vacuum service partner. Our Field Service Team and our fully-equipped Service Technology Centers are at your disposal.

- Oil and spare parts
- Exchange pumps
- Certified used vacuum pumps
- Pump repair centers
- Service agreements
- On-site service
- Pump rentals

LEYCALC

Smart online vacuum system calculation tool

- ✔ **New online tool to help with modeling vacuum systems for various applications, selection and implementation of vacuum pumps and measurement equipment**
- ✔ **With these new web-based tool, users can select and compile their vacuum solutions online**

- Vacuum system calculation tool able to simulate typical vacuum installations
- We make our expert tools available for our customers
- Easy to use, simple handling, intuitive navigation
- Further access to our expert network on demand, e.g for simulation of complex systems
- Proven calculation results, based on Leybold's long time practical experience



calc.leybold.com/en/