

External Vacuum Controller best suitable to control vacuum large flow
External Vacuum Controller VQP Series

- *External Vacuum Controller with 31.5mm in width suitable to control vacuum large flow.*
- *Wide variety of combinations enables to meet various applications. Complex Vacuum Generator, VQ Series, is also available. (P.222).*
 - *2 selections of vacuum supply valve types: normally closed and normally open types.*
- *Visibility improvement by vacuum sensor with 31mm size LED display.*

External Vacuum Controller Series

External Vacuum Controller VQP Series

VACUUM GENERATOR
EXTERNAL VACUUM CONTROLLER

Construction

● Construction (Blow-off)

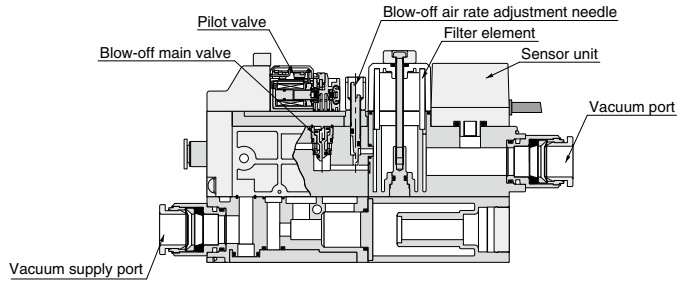

● Construction (Vacuum suction)

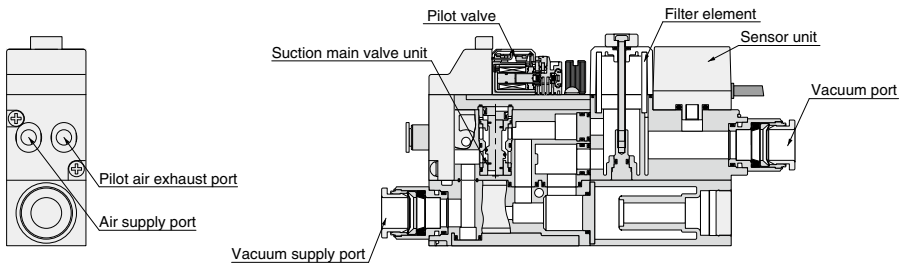

How VQP series works

At vacuum generation suspended

● Blow-off

● Vacuum suction

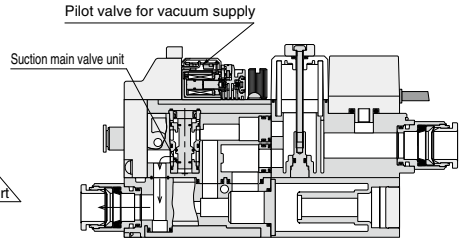
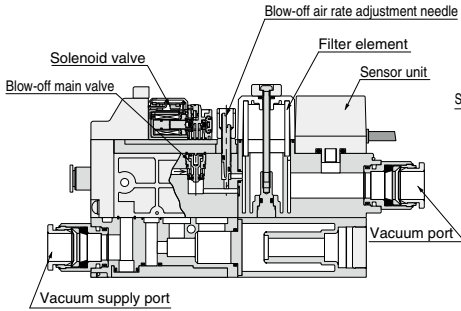

At vacuum generating

● Blow-off

● Vacuum suction

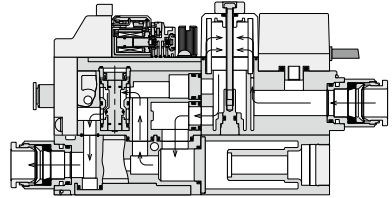
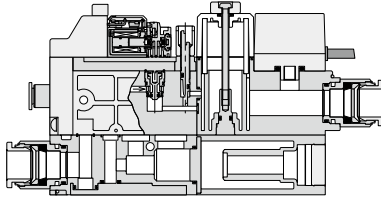

At blow-off air supply

● Blow-off

● Vacuum suction

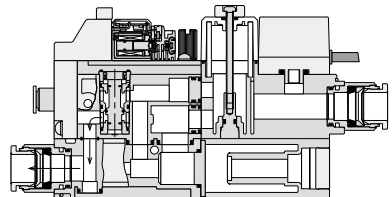
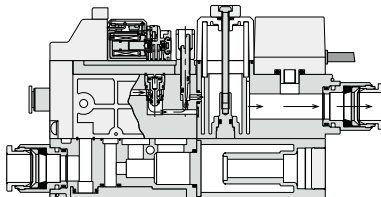

Model Designation (Example)

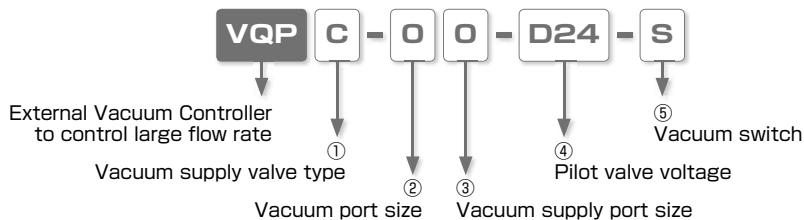

① Vacuum supply valve type

Code	Valve type	Code	Valve type
C	Normally closed type	O	Normally open type

② Vacuum port size (Applicable tube size)

Code	0	2	3
Tube dia.(mm)	ø10 (Push-In Fitting)	ø12 (Push-In Fitting)	ø16 (Push-In Fitting)

③ Vacuum supply port (Applicable tube size)

Code	0	2	3
Tube dia.(mm)	ø10 (Push-In Fitting)	ø12 (Push-In Fitting)	ø16 (Push-In Fitting)

④ Pilot valve voltage

Code	D24	A100
Voltage	DC24V	AC100V

⑤ Vacuum switch

Code	Switch	Code	Switch
S	2 switch output with 31mm LED display	No code	Without vacuum switch

Specification (supply pressure)

Fluid medium	Air
Operating pressure range	0.3 ~ 0.7 MPa
Operating temp. range	5 ~ 50°C
Operating vacuum range	-100 ~ 0kPa

Solenoid valve

Pilot valve

Operating system	Direct operation	
Valve construction	Elastic seal, Poppet valve	
Rated voltage	DC24V	AC100V
Allowable voltage range	DC24V ±10%	AC100V ±10%
Surge protection circuit	Surge absorber	Diode bridge
Power consumption	0.55W	1VA
Manual operation	Push-lock button	
Operation indicator	Coil excitation: Red LED ON	

Switchover valve

Item	Suction main valve	Blow-off main valve
Operating system	Pneumatic operation by pilot valve	
Valve construction	Elastic seal, Poppet valve	
Valve type	N.C. / N.O.	N.C.
Lubrication	Not required	
Effective sectional area (Cv)	16.5mm ² (0.89)	3.5mm ² (0.19)

Vacuum switch

Operating pressure range	-100 ~ 100kPa
Proof pressure	200kPa
Operating temp. range	-10 ~ 50°C (No freezing)
Operating humidity range	35 ~ 85%RH (No dew condensation)
Rated voltage	12 ~ 24VDC ±10%, ripple P-P: 10% or less
Protective structure	IEC standard IP40 equiv.
No. of pressure setting	2
Switch output	NPN open collector output / DC30V 100mA or less / Residual voltage: 1.2V or less (at 100mA load current)
Differential response	0 ~ 30 digit (Variable)
Indication accuracy	Within the range of ±3%F.S.
Response time	5m-sec max.
Indication	2-1/2 digit-7-segmented LED display
Display frequency	About 4 times/sec.
Indication accuracy	±1%F.S. ±1digit
Temperature characteristics	±0.3%F.S. max. (0 ~ 50°C(Standard at 25°C))

External Vacuum Controller Series

External Vacuum Controller VQP Series

VACUUM GENERATOR
EXTERNAL VACUUM CONTROLLER

Filter specification

Element material	PVF(Polyvinyl formal)
Filtering capacity	10 μ m
Filter surface area	1,507mm ²
Replacement element model code	VQ030B61

Blow-off function

Blow-off air rate	0 ~ 50l/min(ANR) (When supply pressure is at 0.5Mpa)
-------------------	--

Valve lead wires

	Black	Gray	Blue	Brown
DC24V	Vacuum suction(-)	Blow-off(-)		DC24V (+ common)
AC100V	Vacuum suction(-)	Blow-off(-)		common

Circuit diagram (Solenoid valve)

DC24V

AC100V



Vacuum switch electric circuit

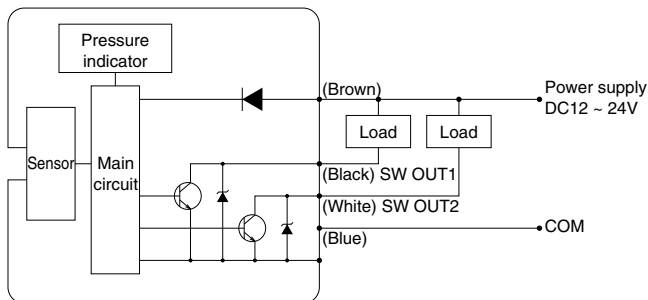

How to insert and disconnect

1. How to insert and disconnect tubes

① Tube insertion

Insert a tube into Push-In Fitting of the External Vacuum Controller VQP up to the tube end. Lock-claws bites the tube to fix it automatically and the elastic sleeve seals around the tube.

Refer to "2. Instructions for Tube Insertion" under "Common Safety Instructions for Fittings" .

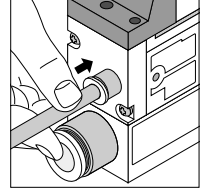

② Tube disconnection

The tube is disconnected by pushing release-ring to release Lock-claws.

Make sure to stop air supply before the tube disconnection.

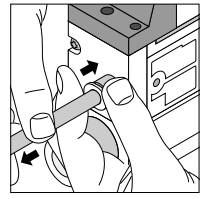

2. How to fix body

In order to fix the External Vacuum Controller VQP, tighten M3 threads through the fixing holes on the resin body with tightening torque 0.3 to 0.35Nm. Refer to the outer dimensional drawings for the hole pitch.

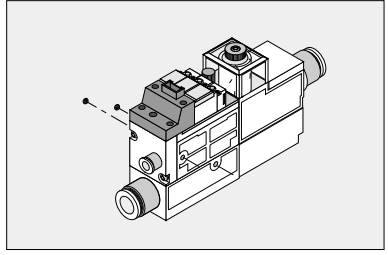

Applicable Tube and Related Products

Polyurethane Tube(1. Piping products catalog P.596)

■ Polyurethane Tube is for the general pneumatic piping and suitable for a compact piping.

Nylon Tube(1. Piping products catalog P.608)

■ Nylon Tube is for the general pneumatic piping and suitable for a high-pressure fluid up to 1.5MPa (NB tube: 1.0MPa).

Vacuum Tube(1. Piping products catalog P.612)

■ Vacuum Tube is a ultra-soft tube and suitable for piping of vacuum generators or actuators.

Vacuum Pads

- Vacuum Pad Standard Series . . . P.428
- Vacuum Pad Sponge Series . . . P.468
- Vacuum Pad Bellows Series . . . P.488
- Vacuum Pad Multi-Bellows Series P.508
- Vacuum Pad Oval Series P.526
- Vacuum Pad Soft Series P.550
- Vacuum Pad Soft Bellows Series P.578
- Vacuum Pad Skidproof Series . . P.604
- Vacuum Pad Ultrathin Series . . P.624
- Vacuum Pad Mark-free Series . . P.642
- Vacuum Pad Long Stroke Series . P.658

External Vacuum Controller Series

External Vacuum Controller VQP Series

VACUUM GENERATOR
 EXTERNAL VACUUM CONTROLLER

Standard Size List

Without vacuum switch

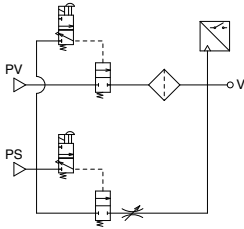

Vacuum switch

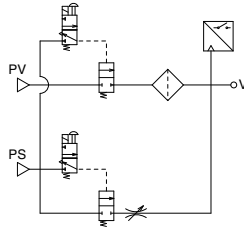

Type	Page to refer	Vacuum port	Vacuum supply port		
			10mm	12mm	16mm
VQP	374	10mm	●	●	●
		12mm	●	●	●
		16mm	●	●	●

Type	Page to refer	Vacuum port	Vacuum supply port		
			10mm	12mm	16mm
VQP	374	10mm	●	●	●
		12mm	●	●	●
		16mm	●	●	●

VQP Without vacuum switch

Model code : VQP□-□□-□

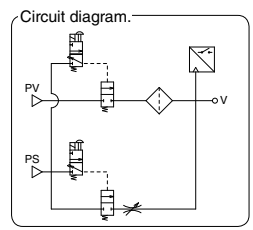
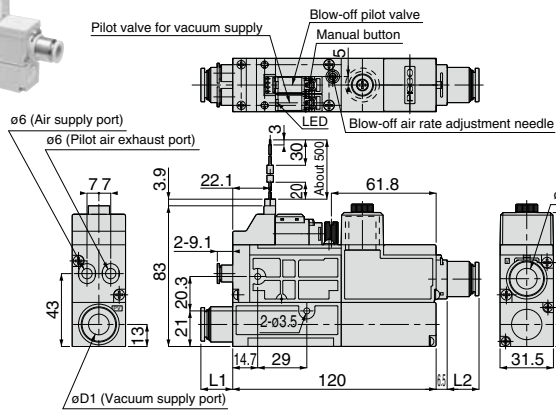
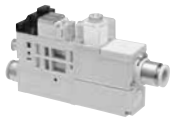

VQP With 2 switch output vacuum switch

Model code : VQP□-□□-□S

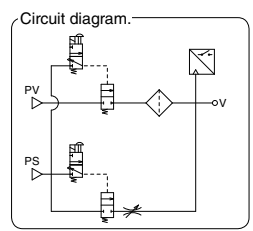
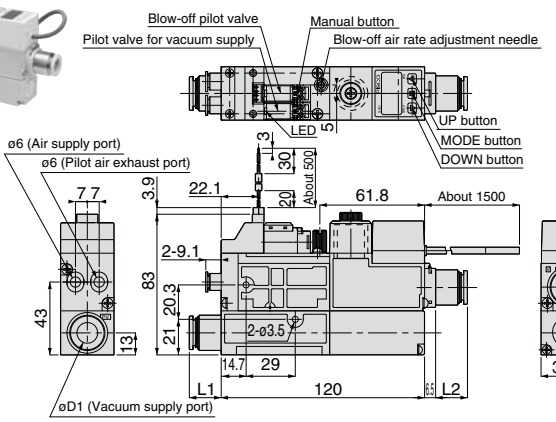

Common dimension list on this page

Unit: mm

	Applicable tube O.D.	L1	Applicable tube O.D.	L2
	øD1	14.7	øD2	-
Vacuum supply port	10	14.7	-	-
	12	18.8	-	-
	16	23.9	-	-
Vacuum port	-	-	10	14.7
	-	-	12	14.7
	-	-	16	23.9

Before using PISCO products, be sure to read "Safety Instructions" and "Safety Instruction Manual" on page 35-39 and "Common Safety Instructions for Vacuum Series" on page 47-49.

Warning

1. Operating temp. range of this series is 5-50°C . Do not operate the product out of this range.
2. The coil in a pilot solenoid valve generates heat under the following ① to ③ conditions. The heat may cause dropping life cycle, malfunctions, getting burnt or damaging peripheral machines. Contact us when the power is applied to the vacuum generator under the following conditions:
 - ① The power is continuously ON for over 2 hours.
 - ② High-cycle operation.
 - ③ Even when intermittent running of the generator is carried out, the total operation time per day is longer than non-operation time.
3. When the electricity is applied to valves continuously for a long time, the coils generate heat. It may cause dropping life cycle, malfunctions, getting burnt or damaging peripheral machines due to the heat.
4. Switchover valve of double-solenoid types is placed in neutral after the supply of pilot air has been suspended (the same is true when the valve is being operated for the first time after shipment). When resuming the supply of pilot air, be sure to send a signal to the pilot valve, or conduct switchover operations manually as required.
5. For the operation of the valve, make sure that the leakage current is less than 1mA. Leakage current larger than that may cause malfunction.
6. Vacuum retention function of External Vacuum Controller permits some vacuum leakage. When vacuum retention for a long period of time is required, provide an appropriate safety measure.
7. Do not use the product in the environment including a corrosive gas.
8. The product is not explosive-proof. Do not use it in the environments containing flammable or explosive gases or liquid. It may cause a fire or an explosion under these environments.
9. Do not use the product out of the operation temperature range. It may cause a malfunction of the sensor by the heat.
10. When wiring, be sure to 1) switch OFF the power, and 2) confirm the color of each lead wire, terminal numbers, etc. in order to prevent the output terminal from being inadvertently short-circuited with the power source and COM terminals. Short-circuits can cause sensor problems.



Caution

1. Compressed air contains many kinds of drains such as water, oxidized oil, tar and other foreign substances. Dehumidify the compressed air by using an after-cooler or a dryer and improve the air quality, since those drains seriously impair the performance of the vacuum generator.
2. Do not use lubricators.
3. Rusts in the pipes may cause malfunction. Place a filter finer than 5 μ m ahead of the air supply port. It is recommended to carry out pipe flushing before operation and on a proper regular basis.
4. Do not give an excessive tensile strength and bending on a lead wire. Otherwise, breaking wire or damage on connector may be caused.
5. Avoid using the vacuum generator under the condition of corrosive and / or inflammable gas. Also do not use these gasses as a fluid medium.
6. The product is not drip/dust proof. Do not use the vacuum generator in location where it may be exposed to water, oil drop or dust.
7. Avoid sucking dust, salt and/or iron powders.
8. Do not operate blow-off solenoid valves during vacuum generation.
9. When replacing supply ports and vacuum ports cartridges, be sure to remove foreign substances sticking to cartridge seals; make sure cartridge fixing pins are properly inserted into the appropriate ports.
10. Use the shortest pipes as much as possible when piping vacuum components (concentrated exhaust, pilot air exhaust and supply units). Using long pipes can prevent vacuum units from performing properly.
11. Supply a stable DC power to the product.
12. Add a surge absorption circuit to relays or solenoid valves, etc. which are to be connected with output terminal and source terminal. Avoid any use which involves over 80mA in current.
13. Ground the FG terminal when using a unit power source such as switching current.
14. Output terminals and other terminals should not be short-circuited.
15. Do not apply excessive loads to external vacuum controller. Subjecting them to excessive loads can damage the equipment.

Safety Rules for Use

- 1. Valve Operation Usage
→ Refer to that for VQ on page 249
- 3. Name of Vacuum Sensor Parts and Operation Method
→ Refer to those for VQ on page 249
- 4. Initial Setting Mode of Vacuum Switch
→ Refer to that for VQ on page 249
- 5. Pressure Setting Mode of Vacuum Switch
→ Refer that for VQ on to page 250
- 6. Vacuum Switch Functions
→ Refer to that for VQ on page 251
- 7. Zero Point Adjustment and Error Message of Vacuum Switch
→ Refer to that for VQ on page 252
- 8. How to replace Filter Elements
→ Refer to that for VQ on page 253
- 11. How to replace Cartridge Fittings
→ Refer to that for VQ on page 254



SAFETY Instructions

This safety instructions aim to prevent personal injury and damage to properties by requiring proper use of PISCO products.

Be certain to follow ISO 4414 and JIS B 8370

ISO 4414 : Pneumatic fluid power...Recommendations for the application of equipment to transmission and control systems.

JIS B 8370 : General rules and safety requirements for systems and their components.

This safety instructions is classified into "Danger", "Warning" and "Caution" depending on the degree of danger or damages caused by improper use of PISCO products.



Danger

Hazardous conditions. It can cause death or serious personal injury.



Warning

Hazardous conditions depending on usages. Improper use of PISCO products can cause death or serious personal injury.



Caution

Hazardous conditions depending on usages. Improper use of PISCO products can cause personal injury or damages to properties.



Warning

1. Selection of pneumatic products

- ① A user who is a pneumatic system designer or has sufficient experience and technical expertise should select PISCO products.
- ② Due to wide variety of operating conditions and applications for PISCO products, carry out the analysis and evaluation on PISCO products. The pneumatic system designer is solely responsible for assuring that the user's requirements are met and that the application presents no health or safety hazards. All designers are required to fully understand the specifications of PISCO products and constitute all systems based on the latest catalog or information, considering any malfunctions.

2. Handle the pneumatic equipment with enough knowledge and experience

- ① Improper use of compressed air is dangerous. Assembly, operation and maintenance of machines using pneumatic equipment should be conducted by a person with enough knowledge and experience.

3. Do not operate machine / equipment or remove pneumatic equipment until safety is confirmed.

- ① Make sure that preventive measures against falling work-pieces or sudden movements of machine are completed before inspection or maintenance of these machine.
- ② Make sure the above preventive measures are completed. A compressed air supply and the power supply to the machine must be off, and also the compressed air in the systems must be exhausted.
- ③ Restart the machines with care after ensuring to take all preventive measures against sudden movements.

Disclaimer

1. PISCO does not take any responsibility for any incidental or indirect loss, such as production line stop, interruption of business, loss of benefits, personal injury, etc., caused by any failure on use or application of PISCO products.
2. PISCO does not take any responsibility for any loss caused by natural disasters, fires not related to PISCO products, acts by third parties, and intentional or accidental damages of PISCO products due to incorrect usage.
3. PISCO does not take any responsibility for any loss caused by improper usage of PISCO products such as exceeding the specification limit or not following the usage the published instructions and catalog allow.
4. PISCO does not take any responsibility for any loss caused by remodeling of PISCO products, or by combinational use with non-PISCO products and other software systems.
5. The damages caused by the defect of Pisco products shall be covered but limited to the full amount of the PISCO products paid by the customer.



SAFETY INSTRUCTION MANUAL

PISCO products are designed and manufactured for use in general industrial machines. Be sure to read and follow the instructions below.

Danger

1. Do not use PISCO products for the following applications.
 - ① Equipment used for maintaining / handling human life and body.
 - ② Equipment used for moving / transporting human.
 - ③ Equipment specifically used for safety purposes.

Warning

1. Do not use PISCO products under the following conditions.
 - ① Beyond the specifications or conditions stated in the catalog, or the instructions.
 - ② Under the direct sunlight or outdoors.
 - ③ Excessive vibrations and impacts.
 - ④ Exposure / adhere to corrosive gas, inflammable gas, chemicals, seawater, water and vapor. *
 - * Some products can be used under the condition above(④), refer to the details of specification and condition of each product.
2. Do not disassemble or modify PISCO products, which affect the performance, function, and basic structure of the product.
3. Turn off the power supply, stop the air supply to PISCO products, and make sure there is no residual air pressure in the pipes before maintenance and inspection.
4. Do not touch the release-ring of push-in fitting when there is a working pressure. The lock may be released by the physical contact, and tube may fly out or slip out.
5. Frequent switchover of compressed air may generate heat, and there is a risk of causing burn injury.
6. Avoid any load on PISCO products, such as a tensile strength, twisting and bending. Otherwise, there is a risk of causing damage to the products.
7. As for applications where threads or tubes swing / rotate, use Rotary Joints, High Rotary Joints or Multi-Circuit Rotary Block only. The other PISCO products can be damaged in these applications.
8. Use only Die Temperature Control Fitting Series, Tube Fitting Stainless SUS316 Series, Tube Fitting Stainless SUS316 Compression Fitting Series or Tube Fitting Brass Series under the condition of over 60°C (140° F) water or thermal oil. Other PISCO products can be damaged by heat and hydrolysis under the condition above.
9. As for the condition required to dissipate static electricity or provide an antistatic performance, use EG series fitting and antistatic products only, and do not use other PISCO products. There is a risk that static electricity can cause system defects or failures.
10. Use only Fittings with a characteristic of spatter-proof such as Anti-spatter or Brass series in a place where flame and weld spatter is produced. There is a risk of causing fire by sparks.
11. Turn off the power supply to PISCO products, and make sure there is no residual air pressure in the pipes and equipment before maintenance. Follow the instructions below in order to ensure safety.
 - ① Make sure the safety of all systems related to PISCO products before maintenance.
 - ② Restart of operation after maintenance shall be proceeded with care after ensuring safety of the system by preventive measures against unexpected movements of machines and devices where pneumatic equipment is used.
 - ③ Keep enough space for maintenance when designing a circuit.
12. Take safety measures such as providing a protection cover if there is a risk of causing damages or fires on machine / facilities by a fluid leakage.

⚠ Caution

1. Remove dusts or drain before piping. They may get into the peripheral machine / facilities and cause malfunction.
2. When inserting an ultra-soft tube into push-in fitting, make sure to place an Insert Ring into the tube edge. There is a risk of causing the escape of tube and a fluid leakage without using an Insert Ring.
3. The product incorporating NBR as seal rubber material has a risk of malfunction caused by ozone crack. Ozone exists in high concentrations in static elimination air, clean-room, and near the high-voltage motors, etc. As a countermeasure, material change from NBR to HNBR or FKM is necessary. Consult with PISCO for more information.
4. Special option "Oil-free" products may cause a very small amount of a fluid leakage. When a fluid medium is liquid or the products are required to be used in harsh environments, contact us for further information.
5. In case of using non-PISCO brand tubes, make sure the tolerance of the outer tube diameter is within the limits of Table 1.

● Table 1. Tube O.D. Tolerance

mm size	Nylon tube	Polyurethane tube	inch size	Nylon tube	Polyurethane tube
ø1.8mm	—	± 0.05mm	ø1/8	± 0.1mm	± 0.15mm
ø3mm	—	± 0.15mm	ø5/32	± 0.1mm	± 0.15mm
ø4mm	± 0.1mm	± 0.15mm	ø3/16	± 0.1mm	± 0.15mm
ø6mm	± 0.1mm	± 0.15mm	ø1/4	± 0.1mm	± 0.15mm
ø8mm	± 0.1mm	± 0.15mm	ø5/16	± 0.1mm	± 0.15mm
ø10mm	± 0.1mm	± 0.15mm	ø3/8	± 0.1mm	± 0.15mm
ø12mm	± 0.1mm	± 0.15mm	ø1/2	± 0.1mm	± 0.15mm
ø16mm	± 0.1mm	± 0.15mm	ø5/8	± 0.1mm	± 0.15mm

6. Instructions for Tube Insertion

- ① Make sure that the cut end surface of the tube is at right angle without a scratch on the surface and deformations.
- ② When inserting a tube, the tube needs to be inserted fully into the push-in fitting until the tubing edge touches the tube end of the fitting as shown in the figure below. Otherwise, there is a risk of leakage.

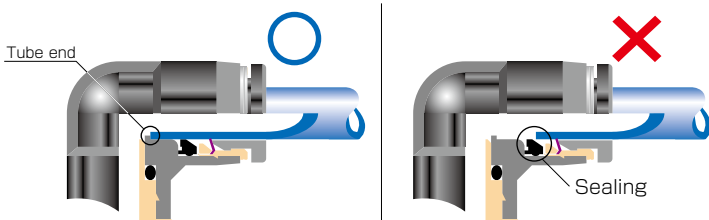

Tube is not fully inserted up to tube end.

- ③ After inserting the tube, make sure it is inserted properly and not to be disconnected by pulling it moderately.
- ※ When inserting tubes, Lock-claws may be hardly visible in the hole, observed from the front face of the release-ring. But it does not mean the tube will surely escape. Major causes of the tube escape are the followings;
- ① Shear drop of the lock-claws edge
 - ② The problem of tube diameter (usually small)
- Therefore, follow the above instructions from ① to ③, even lock-claws is hardly visible.

7. Instructions for Tube Disconnection

- ① Make sure there is no air pressure inside of the tube, before disconnecting it.
- ② Push the release-ring of the push-in fitting evenly and deeply enough to pull out the tube toward oneself. By insufficient pushing of the release-ring, the tube may not be pulled out or damaged by scratch, and tube shavings may remain inside of the fitting, which may cause the leakage later.

8. Instructions for Installing a fitting

- ① When installing a fitting, use proper tools to tighten a hexagonal-column or an inner hexagonal socket. When inserting a hex key into the inner hexagonal socket of the fitting, be careful so that the tool does not touch lock-claws. The deformation of lock-claws may result in a poor performance of systems or an escape of the tube.
- ② Refer to Table 2 which shows the recommended tightening torque. Do not exceed these limits to tighten a thread. Excessive tightening may break the thread part or deform the gasket and cause a fluid leakage. Tightening thread with tightening torque lower than these limits may cause a loosened thread or a fluid leakage.
- ③ Adjust the tube direction while tightening thread within these limits, since some PISCO products are not rotatable after the installation.

● Table 2: Recommended tightening torque / Sealock color / Gasket materials

Thread type	Thread size	Tightening torque	Sealock color	Gasket materials
Metric thread	M3 × 0.5	0.7N·m	—	SUS304 NBR
	M5 × 0.8	1.0 ~ 1.5N·m		
	M6 × 1	2 ~ 2.7N·m		
	M3 × 0.5	0.5 ~ 0.6N·m		POM
	M5 × 0.8	1 ~ 1.5N·m		
	M6 × 0.75	0.8 ~ 1N·m		
Taper pipe thread	M8 × 0.75	1 ~ 2N·m	White	—
	R1/8	7 ~ 9N·m		
	R1/4	12 ~ 14N·m		
	R3/8	22 ~ 24N·m		
Unified thread	R1/2	28 ~ 30N·m	—	SUS304, NBR
	No.10-32UNF	1.0 ~ 1.5N·m		
National pipe thread taper	1/16-27NPT	7 ~ 9N·m	White	—
	1/8-27NPT	7 ~ 9N·m		
	1/4-18NPT	12 ~ 14N·m		
	3/8-18NPT	22 ~ 24N·m		
	1/2-14NPT	28 ~ 30N·m		

※ These values may differ for some products. Refer to each specification as well.

9. Instructions for removing a fitting

- ① When removing a fitting, use proper tools to loosen a hexagonal-column or an inner hex bolt.
- ② Remove the sealant stuck on the mating equipment. The remained sealant may get into the peripheral equipment and cause malfunctions.

10. Arrange piping avoiding any load on fittings and tubes such as twist, tensile, moment load, shaking and physical impact. These may cause damages to fittings, tube deformations, bursting and the escape of tubes.



Common Safety Instructions for Vacuum Series

Before selecting or using PISCO products, read the following instructions. Read the detailed instructions for individual series.

Warning

1. If there is a risk of dropping work-pieces during vacuum suction, take a safety measure against the falling of them.
2. Avoid supplying more than 0.1MPa pressure constantly in a vacuum circuit. Since vacuum generators are not explosive-proof, there is a risk of damaging the products.
3. Pay attention to drop of vacuum pressure caused by problems of the supplied air or the power supply. Decrease of suction force may lead to a danger of falling work-piece so that safety measure against the falling of them is necessary.
4. When more than 2 vacuum pads are plumbed on a single ejector and one of them has a suction problem such as vacuum leak, there is a risk of releasing work-pieces from the other pad due to the drop of the vacuum pressure.
5. Do not use in the way by which exhaust port is blocked or exhaust resistance is increased. Otherwise, there is a risk of no vacuum generation or a drop of the vacuum pressure.
6. Do not use the product in the circumstance of corrosive gas, inflammable gas, explosive gas, chemicals, seawater and vapor or do not expose the product to those. Never allow the product to suck those things.
7. Provide a protective cover on the products when it is exposed to sunlight.
8. Carry out clogging check for silencer element in an ejector and a vacuum filter periodically. Clogged element will be a cause to impair the performance or a cause of troubles.
9. Before replacing the element, thoroughly read and understand the method of filter replacement in the catalog.
10. Make sure the correct port of the vacuum generator by this catalog or marking on the products when plumbing. Wrong plumbing can be a risk to damage the product.
11. Supply clean air without sludge or dusts to an ejector. Do not lubricate by a lubricator. There is a risk of malfunction or performance impairing by impurities and oil contained in the compressed air.
12. Do not apply extreme tension, twist or bending forces on a lead wire. Otherwise, it may cause a wire breaking.
13. Locknut needs to be tightened firmly by hand. Do not use any tool to tighten. In case of using tools to tighten the locknut, it may damage the locknut or the product. Inadequate tightening may loosen the locknut and the initial setting can be changed.
14. Do not force the product to rotate or swing even its resin body is rotatable. It may cause damage to the product and a fluid leakage.
15. Do not supply an air pressure or a dry air to the products over the necessary amount. There is a risk of deteriorating rubber materials and malfunction due to oil.
16. Keep the product away from water, oil drops or dusts. These may cause malfunction. Take a proper measure to protect the product before the operation.

17. Do not use the product in the environment of inflammable or explosive gas / fluid. It can cause a fire or an explosion hazard.
18. Do not use the product in the circumstance of corrosive gas, inflammable gas, explosive gas, chemicals, seawater and vapor or do not expose the product to those. Otherwise, it may be a cause of malfunction.
19. Do not clean or paint the products by water or a solvent.

⚠ Caution

1. Operating pressure range in the catalog is the values during ejector operation. Secure the described value of the supplied air, taking a drop of the pressure into consideration. Insufficient pressure, which does not satisfy the spec, may cause abnormal noise, unstable performance and may negatively affect sensors, bringing troubles at last.
2. Effective cross-section area of the air supply side needs to be three times as large as effective cross-section area of the nozzle bore. When arranging piping or selecting PISCO products, secure required effective cross-section area. Insufficient supply pressure may be a cause to impair performance.
3. A Shorter distance of plumbing with a wider bore is preferable at vacuum system side. A long plumbing with a small bore may result in slow response time at the time of releasing work-piece as well as in failure to secure adequate suction flow rate.
4. Plumb a vacuum switch and an ejector with vacuum switch at the end of vacuum system as much as possible. A long distance between a vacuum switch and a vacuum system end may increase plumbing resistance which may lead to a high vacuum level at the sensor even when no suctioning and a malfunction of vacuum switch. Make sure to evaluate the products in an actual system.
5. Refer to "4. Instructions for Installing a fitting" and "5. Instructions for Removing a fitting" under "Common Safety Instructions for Fittings" , when installing or removing Fittings.
6. Refer to "Common Safety Instructions for Pressure Sensors" and "Detailed Safety Instructions" for the handling of digital vacuum switch sensor.
7. Refer to "Common Safety Instructions for Mechanical Vacuum Sensor" for the handling of mechanical vacuum switch.
8. The material of plastic filter cover for VG, VK, VJ, VZ and VX series is PCTG. Avoid the adherence of Chemicals below to the products, and do not use them under those chemical environments.

● Table Chemical Name

Chemical Name
Thinner
Carbon tetrachloride
Chloroform
Acetate
Aniline
Cyclohexane
Trichloroethylene
Sulfuric acid
Lactic acid
Water soluble cutting oil (alkaline)

* There are more chemicals which should be avoided. Contact us for the use under chemical circumstance.

VACUUM GENERATOR
EXTERNAL VACUUM CONTROLLER
VACUUM PAD
VACUUM ACCESSORIES
48
VH-VS
VU
VUM
VY
VB
VM-VC
VRL
VG
VK
VJ
VX
VQ
VZ
VN

9. The material of plastic filter cover for VQ and VFU series is PA. Avoid the adherence of chemicals below to the products, and do not use them under those chemical environments.

● Table Chemical Name

Chemical Name
Methanol
Ethanol
Nitric acid
Sulfuric acid
Hydrochloric acid
Lactic acid
Acetone
Chloroform
Aniline
Trichloroethylene
Hydrogen peroxide

* There are more chemicals which should be avoided. Contact us for the use under chemical circumstance.