

Plarailchain HPC

Characteristics

- The flaps break open in the middle, so that you can add or remove cables simply by pushing or pulling. (Upon receiving the chains, you need to cut the flaps along the middle with a cutter or nipper, however.)

Calculation of Number of Links

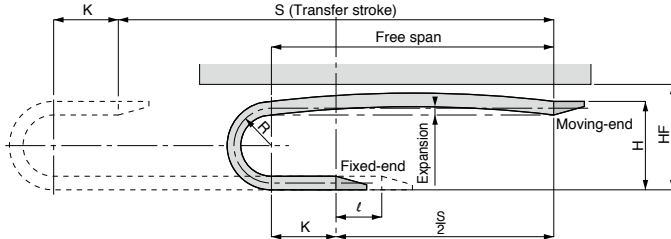

* HF in the chart above is the height which Plarailchain is able to pass through using under the length of free span with allowable expansion without load such as cables, hoses, etc.
* Please make inquiries for special travel conditions.

Series	R		H		HF		K		a	
	mm	inch	mm	inch	mm	inch	mm	inch	mm	inch
HPC203	30	1.18	98	3.86	120	4.72			144.2	5.68
	45	1.77	128	5.04	150	5.90	25	0.98	191.3	7.53
	60	2.36	158	6.22	180	7.08			238.4	9.38
HPC204	50	1.97	146	5.75	165	6.49			271.0	10.67
	90	3.54	226	8.90	245	9.64	30	1.18	342.6	13.49
	150	5.90	346	13.62	365	14.37			531.0	20.90
HPC306	50	1.97	160	6.30	177	6.97			257.0	10.12
	100	3.94	260	10.23	277	10.90	50	1.97	414.0	16.30
	150	5.90	360	14.17	377	14.84			571.0	22.47
HPC50	60	2.36	152	5.98	206	8.11	90	3.54	368.4	14.50
HPC100	90	3.54	227	8.93	257	10.12	90	3.54	462.6	18.21
HPC200	105	4.13	260	10.23	295	11.61	90	3.54	509.7	20.06

Number of links is to be calculated by the following equation:

$$n = \frac{\frac{S}{2} + a + l}{P}$$

n: Number of links (Figures below decimal point are raised to one positive number)
S: Transfer stroke (mm or inch)
a: $\pi R + 2K$ (R: Bending radius (mm or inch), K: Play (mm or inch))
l: Distance from intermediate point (mm or inch) when the fixed-end is not in the middle of transfer stroke (when the transfer stroke is in the intermediate point : 0)
P: Pitch (mm or inch)

<Note>
Setting fixed-end in the intermediate point of transfer stroke minimizes required number of Plarailchain.

Detailed Safety Instructions

Before using PISCO products, be sure to read "Safety Instructions" and "Common Safety Instructions for Products in This Catalog" on page 13 to 16 and "Common Safety Instructions for Plarailchain" on page 24 to 29.

Specifications

Type		203	204	306	50	100	200
Max. transfer stroke	m	1.4	1.7	1.8	1.9	1.9	1.9
	ft	4.59	5.58	5.91	6.23	6.23	6.23
Max. contents weight	kg/m	2.5	4	7	1	0.5	0.5
	lb./ft	1.68	2.69	4.70	0.67	0.34	0.34
Max. transfer speed		2.50m/sec. or 8.20ft/sec.					
Plarailchain weight	kg/m	0.37	0.59	0.78	0.358	0.608	0.34
	lb./ft	0.25	0.40	0.52	0.24	0.41	0.71
Plarailchain material		Nylon 6 (glass 20%)					
Bracket material		SPCC with chrome plating (RoHS compliance)			SPCC with black chrome plating (RoHS compliance)		
		14 ~ 176°F / -10 ~ 80°C					
Service temp. range		14 ~ 176°F / -10 ~ 80°C					
Operating environment		Avoid using in acid/alkaline atmosphere or in hot water					

Model Designation (Example) (New size)

HPC **203** - **R30**
(1) (2)

(1) Size (Overall dimensions: H × W)

Code	203	204	306
Size	mm 29×48	34×69	47×78
	in. 1.14×1.89	1.34×2.72	1.85×3.07

(2) Bending radius

Code	R30	R45	R50	R60	R90	R100	R150
203	○	○		○			
204			○		○		○
306			○			○	○

* Two kinds of brackets, one for fixed-end and the other for moving-end, are required. Select a designation code for the bracket from page 38.

▶ In case of ordering, please apply Model code in the following chart.

Model Designation (Example)

HPC **100**
(1)

(1) Size (Overall dimensions: H × W)

Code	50	100	200
Size	mm 26×48	37×69	44×84
	in. 1.02×1.89	1.46×2.72	1.73×3.31
Bending radius	mm 60	90	105
	in. 2.36	3.54	4.13

* Two kinds of brackets, one for fixed-end and the other for moving-end, are required. Select a designation code for the bracket from page 38.

▶ In case of ordering, please apply Model code in the following chart.

RoHS The products listed in this page are ECO-friendly products.
* Please refer to page 4 for the details of ECO-friendly products.

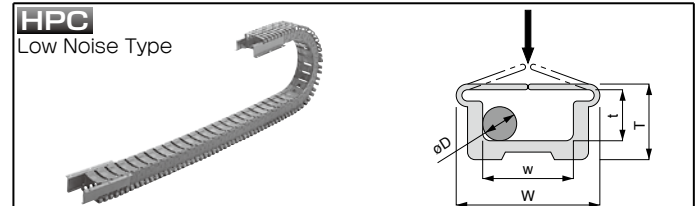







Model code	No. of links		Pitch		W		T		w		t		øD (max.)		Free span	
	/m	/ft.	mm	inch	mm	inch	mm	inch	mm	inch	mm	inch	mm	inch	m	ft.
HPC203-R30	40	12	25	0.98	48	1.89	29	1.14	28	1.10	24.5	0.96	19	0.75	0.75	2.46
HPC203-R45																
HPC203-R60																
HPC204-R50	32	10	32	1.26	69	2.72	34	1.34	40	1.57	29	1.14	23	0.91	1.0	3.28
HPC204-R90																
HPC204-R150																
HPC306-R50	23	7	45	1.77	78	3.07	47	1.85	44	1.73	39.5	1.55	30	1.18	1.0	3.28
HPC306-R100																
HPC306-R150																
HPC50	40	12	25	0.98	48	1.89	26	1.02	28	1.10	20.5	0.81	16	0.63	1.0	3.28
HPC100	40	12	25	0.98	69	2.72	37	1.46	40	1.57	30	1.18	24	0.94	1.0	3.28
HPC200	40	12	25	0.98	84	3.31	44	1.73	54	2.13	35.5	1.40	28	1.10	1.0	3.28

Caution
* Free span is the maximum length that Plarailchain can travel horizontally.
* The metal brackets must be ordered separately. (See P. 38)
* Make-to-order production

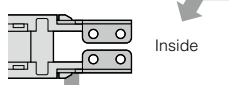
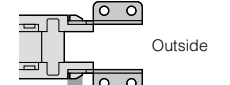
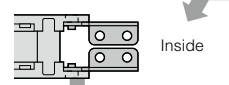
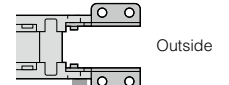

The products listed in this page are ECO-friendly products.
 * Please refer to page 4 for the details of ECO-friendly products.

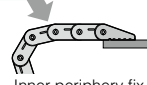
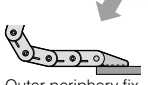
Metal Brackets for Attachment of Plarailchain (HPC203, 204, 306)

Use	For moving-end				For fixed-end			
Bracket type	 Hole type (for moving-end)				 Pivot type (for fixed-end)			
Screwing position	 Inside		 Outside		 Inside		 Outside	
Orientation	 Outer periphery fix		 Inner periphery fix		 Outer periphery fix		 Inner periphery fix	
Type	Model code	Model code	Model code	Model code	Model code	Model code	Model code	Model code
HPC203	U2-MAO-S	U2-MAI-S	U2-MAO-S	U2-MAI-S	U2-FAO-S	U2-FAO-S	U2-FBO-S	U2-FBO-S
HPC204	U2-MAO	U2-MAI	U2-MAO	U2-MAI	U2-FAO	U2-FAO	U2-FBO	U2-FBO
HPC306	U3-MAO	U3-MAO	U3-MAO	U3-MAO	U3-FAO	U3-FAI	U3-FBO	U3-FBI



Caution
 * Select best-suited bracket for your application from above selection. Moving-end (the hole type) and fixed-end (the pivot type) must be ordered separately when you need them both.

Metal Brackets for Attachment of Plarailchain (HPC50, 100, 200)

Select best-suited bracket for your application from following selection. Moving-end and fixed-end must be ordered separately when you need them both.

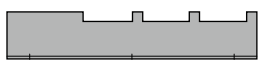
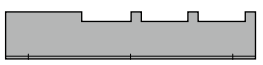
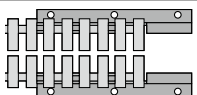
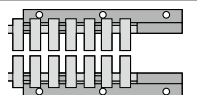
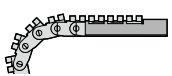
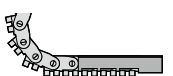
Use	For moving-end	For fixed-end
Bracket type	 for moving-end	 for fixed-end
Screwing position	 Outside	 Outside
Orientation	 Inner periphery fix	 Inner periphery fix
Type	Model code	Model code
HPC50	HPC50-K*	HPC50-K*
HPC100	HPC100-K*	HPC100-K*
HPC200	HPC200-K*	HPC200-K*



Caution
 * Same brackets are used for moving-end and fixed-end. Therefore, two sets are required for moving-end and fixed-end.



Common Safety Instructions for Plarailchain

- Before selecting or using PISCO products, read the following instructions. Read the detailed instructions for individual series as well as the instructions below.

- ⚠Warning :
1. Never step on Plarailchain. Otherwise the chain may break and you will fall down.
 2. When connecting, opening, closing, or carrying out maintenance and checks, hold the Plarailchain motionless. Otherwise the Plarailchain may run or fall under its own weight, thus doing injuries to you.
 3. Pay attention to the flexing areas of the Plarailchain. You can get injured with your hand caught in the flexing area.
 4. Before conducting maintenance or checks of Plarailchain, be sure to turn off power supply to the equipment for your safety.
 5. The Plarailchain should only be used within stated specifications and conditions.
 6. Never perform disassembly or remodeling that can affect the basic structure, performance or function of the equipment.
 7. Please tighten it surely so that a fitting does not loosen. There is danger to cause the damage of the whole system when the slack occurs.
 8. An inertial force, mass load, and reactive force (the force that Plarailchain is going to lug out) are added to the mount of the Plarailchain depending on the specification of the system. When designing the mount, please secure sufficient strength. There is danger to cause the damage of the whole system when the strength of the mount is not enough.

In addition, the reactive force can be obtained from the capability diagram of each Plarailchain.

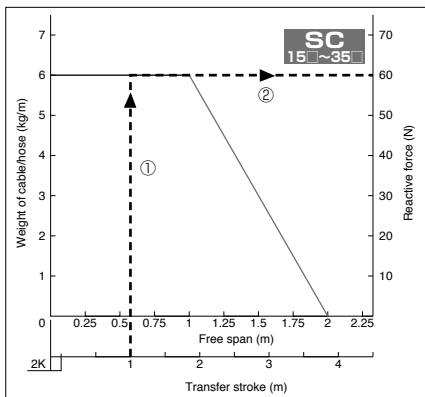

- ① By the capability diagram of the target model, straight up at the transfer stroke value. (as for left diagram, it is the case when the transfer stroke value of the system is 1m.)
- ② From the crossing point with the capability curve, tracing it to the direction of reactive force axis. Intersected value becomes the maximum reactive force. (in the case of the left graph, the value is 60N.)

9. When attaching/detaching caps of SP series, please pay attention not to injure your hands by a screwdriver.

- ⚠Caution :
1. Please check "Plarailchain capability diagrams" well and please choose the most suitable Plarailchain. In addition, please use it after testing it because various factors influence on actual usage.
 2. The Plarailchain lugs out without contents because it is designed to prevent growing down when contents is filled.
 3. The length of Plarailchain can be adjusted by increasing and decreasing. When designing or length adjustment is necessary, please calculate the number of the necessary links with confirming the link calculating formula in this catalogue.
 4. When installing Plarailchain on equipment, please attach the brackets of moving end and fixed end in parallel along the traveling axis. In addition, it becomes the cause of damaging the whole system when the twisting movement is involved.
 5. Cables and hoses to be stored must be flexible and wear-resistant. Do not use wire-braided ones, which are prone to damage.
 6. When weight of cable and hose is heavy, and transfer speed or acceleration is fast, around the bending position may lug out by inertia at start or right after stop. When designing the system, please secure enough HF dimensions.
 7. For use under special circumstances, contact our nearest sales office.
 8. The total volume of contents (tube, hose or cable) to be fitted into Plarailchain should be arranged not to exceed 60% (70% for SP and SC type) of its inside capacity of each model.
 9. Contents should be lined up without crossing each other when they are stored into Plarailchain.
 10. Contents should be stored well balanced in right, left, up, and down.
 11. Avoid applying excessive forces to Metal Brackets.
 12. In case of different contents such as air tubes, water tubes, cables, and/or etc. are stored into the same body, please select bending radius of Plarailchain according to the largest bending radius among the contents.

Capability Diagram

When total weight and max. diameter of cable hose, and transfer stroke are decided, please select a best suitable Parailchain from the following capability diagram. The bending radius of Parailchain must be larger than the one of cable/hose.

Remarks

1. F = Free span = Length can be travelled horizontally
2. The diagram is a case when fixed-end is set to the center of transfer stroke.
3. ϕ : Maximum diameter of cable or hose to be stored.

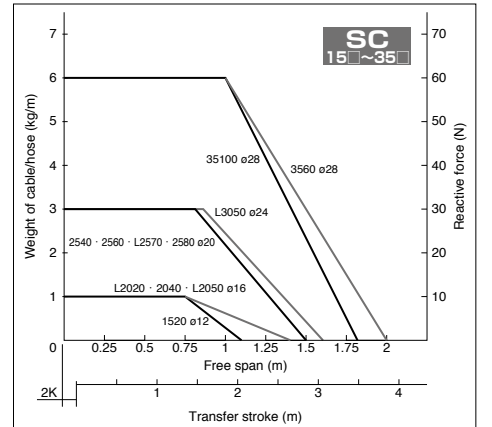
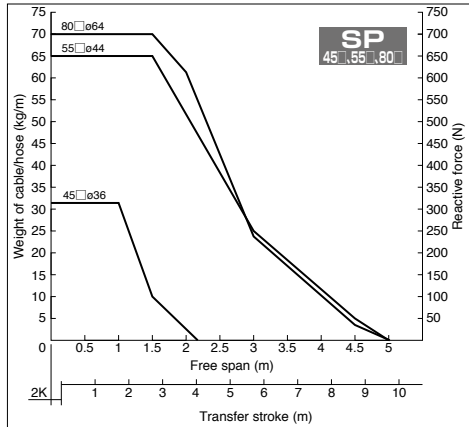
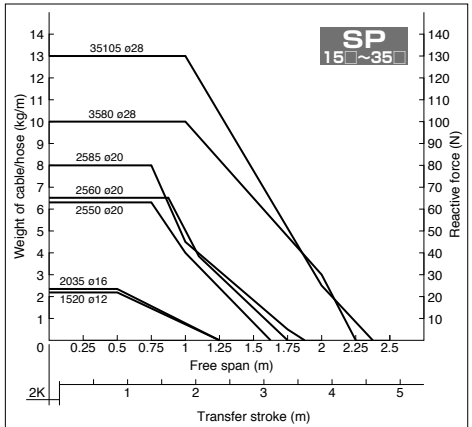
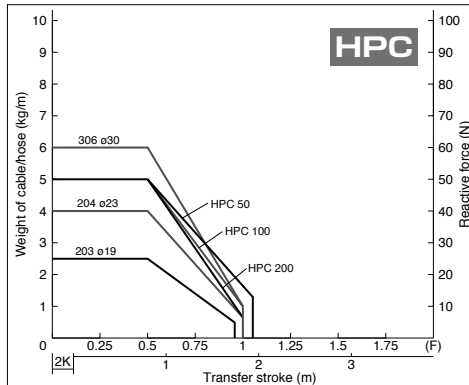
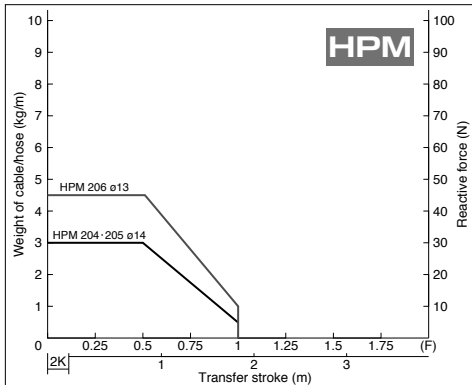
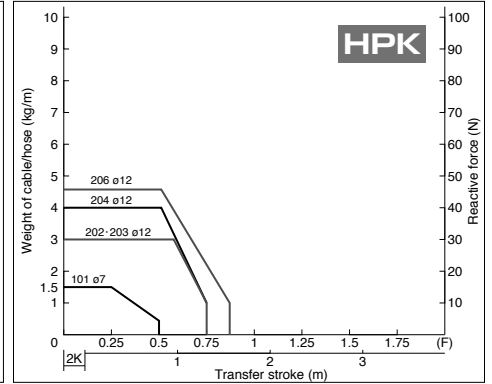
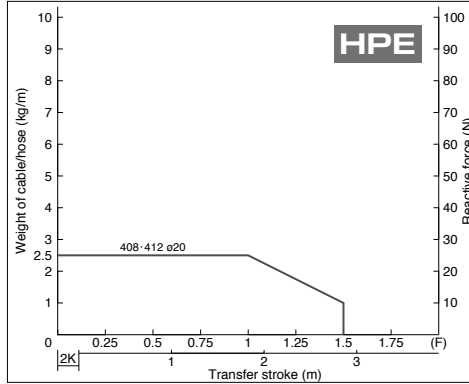
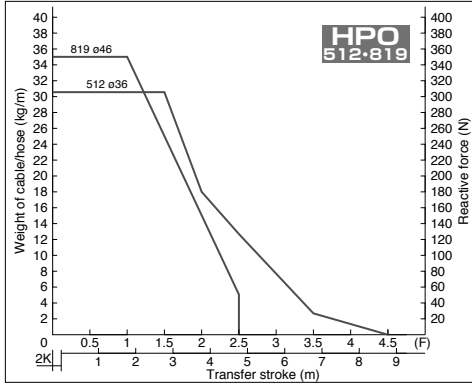
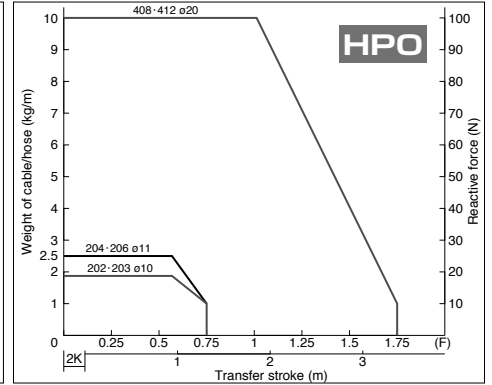
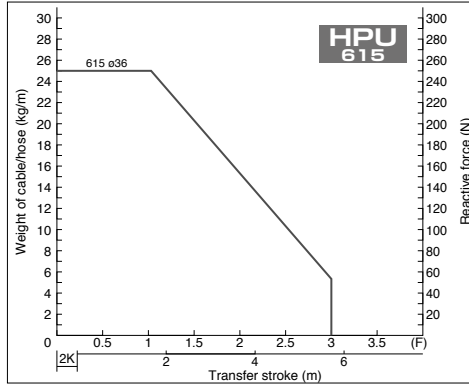
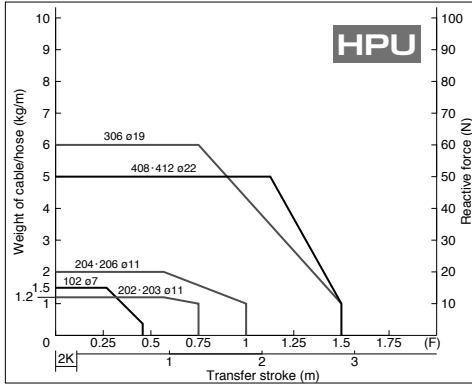



⚠ Safety Instructions for fixing storage items (tubings/ cables)

□ This instruction is only examples to decrease the wear and tear of tubings/ cables inside the Plarailchain, but do not guarantee the effect for all types. As such, please conduct test use before actual operation.

1. Storage of tubings/cables

1. Please select tubings/cables with less than the minimum-bending radius of plarailchain. In addition, please fix crook of tubings/ cables before installing in Plarailchain.
2. When plenty of tubings/cables are installed, please use "divider" or "rack" inside in order to avoid spiral twist of the contents.

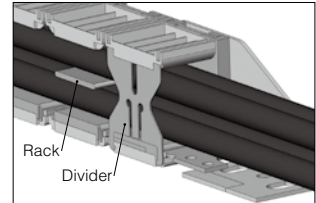

3. Other than partition by divider or rack, partition by a sheet with low surface sliding resistance such as fluorine resin sheet or equivalent can be possible. The sheet with 0.3-0.5mm thickness is recommended. Thinner sheet might stretch and resulting wavelike block, bending, overlapping, tear, and unnecessary load to storage items, which possibly cause troubles. Furthermore, when the sheet is too thick or the sheet tension is stronger than storage items, they might rub them unnecessary against inner wall of Plarailchain and cause early wear and tear.

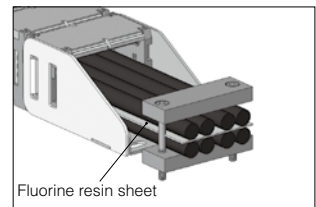

4. Please maintain adequate length of tubings/cables so as not to be overloaded inside Plarailchain.

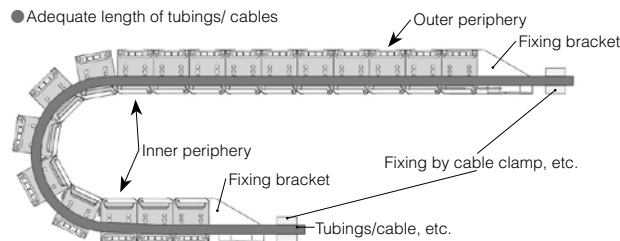

① Troubles caused by too long tubings/cables

- Abrasion (wire disconnection, etc.) by excessive contact with inside outer periphery wall of Plarailchain.
- Entanglement of Tubings/cables
- Protrusion of tubings/ cables from the clearance between flaps of Plarailchain.

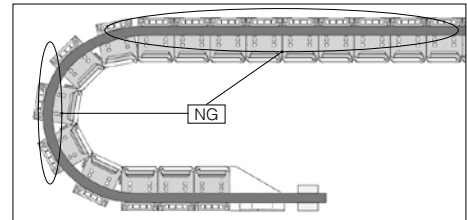

② Troubles caused by too short tubings/cables

- Abrasion (wire disconnection, etc.) by excessive contact with inside inner periphery wall of Plarailchain.

Countermeasure ①

After storing tubings/cables at the stroke end condition in the installed device, please make sure that they are not too long or too short in the range of full transfer stroke

Countermeasure ②

To get a rough idea, fix tubings/ cables by a cable clamp, etc. at one side of fixing bracket, and then pull them lightly at the other side to check if there is no loosening condition (Tubings/cables touch to inner wall of Plarailchain). From that position, loosen tubings/cables about 5mm~10mm (0.197~0.394in.) and fix them by cable clamps, etc., which realizes approximate adequate length. However, there are exceptions depending on the types of tubings/cables.

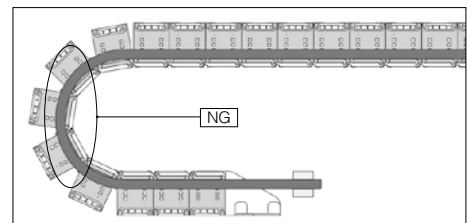

2. Fixing of tubings/cables

1. Please fix tubings/cables as close as possible to the fixing bracket at both ends. Fixing far apart from the bracket causes looseness of the tubings/ cables.
2. Applying metal or resin plates with large surface friction resistance as fixture is acceptable. Tuck tubings/cables between base part and plate as shown below.
Note) When a number of tubings/cables are fixed by a banding band together as shown below, some of them might not be touched and fixed by the band and causes loosening.

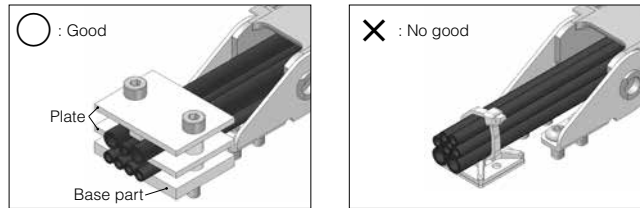

3. When a number of tubings/cables are fixed by banding band, please fix them one by one. If it is not possible due to space shortage, try to make a bundle of few tubings/cables.

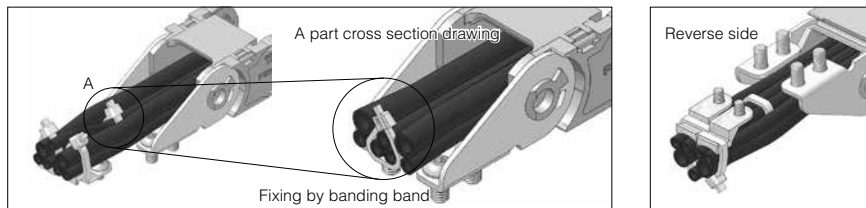



⚠ Safety Instructions for safety device (guide-rail) installation

□ When Plarailchain is used in long stroke or for long time even within the acceptable value of the free-span, the installation of safety device such as guide-rail can prevent sagging or loosening of Plarailchain. (However, the moving speed and acceleration speed are limited by the installation.) Moreover, since the following instruction is only rough indication, please contact PISCO for details.

1. Installation of guide-rail and guide-roller

* Do not use guide-roller for the application of more than 1m/s moving speed. Please consider guide-rail installation instead.

● Installation of guide-rail

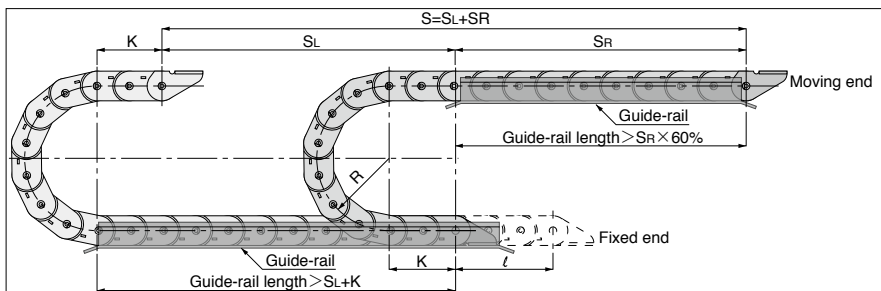

● Installation of guide-roller

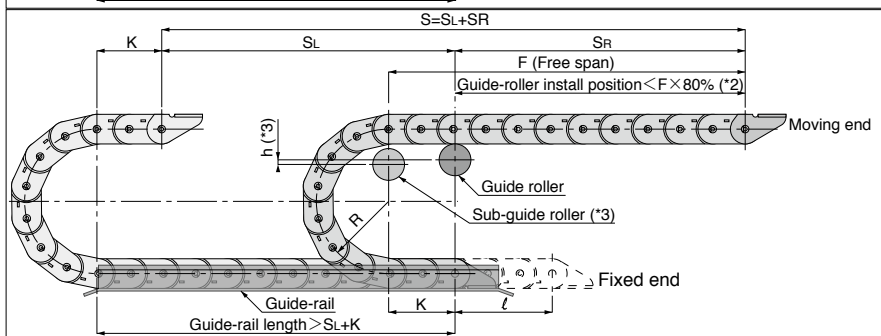

- S: Transfer stroke
- SL: $S/2$ (When fixed end is located in the middle of transfer stroke)
- SR: $S/2$ (When fixed end is located in the middle of transfer stroke)
- K: Required minimum allowance length
- l: Distance from middle point when fixed end is not located in the middle point of transfer stroke

*1. Please create bending guide and avoid edge shape at the end of guide-rail.

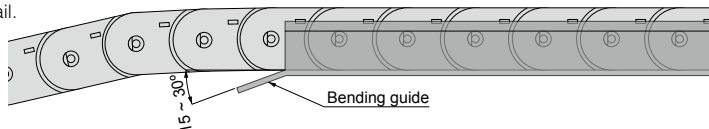

*2. Multiple guide-rollers are required for the application using more than allowable free-span value. In this case, please contact PISCO.

*3. We recommend installing sub-guide-roller in order to put Plarailchains smoothly on the guide-roller when the moving end moves from SL side to SR side. Since the install dimension differs by specification, please contact PISCO.

2. Rough dimensions for guide-rail design

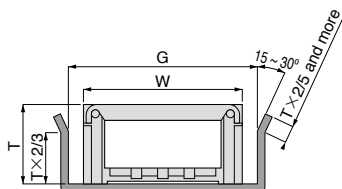

1. Estimation of G dimension

- $W < 100\text{mm}$
 $G = W + 5 \sim 10\text{mm}$
- $W > 100\text{mm}$
 $G = W + 15 \sim 20\text{mm}$

* As above dimensions are only rough and they differ by the specification, please contact PISCO for details.

3. Operation of multiple movements

When biaxial running or multiple movements are operated as shown below, please confirm the specification and contact PISCO.

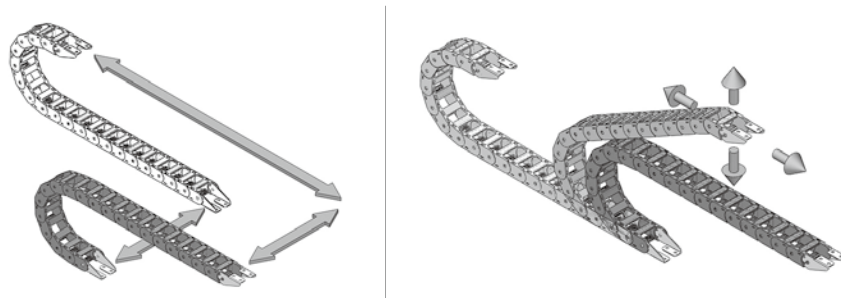

4. Other safety instructions for long stroke and multiple movements operation

1. Using safety devices such as guide-rail or guide-roller cause abrasion where the devices and Plarailchain contact. As such, please apply material made of low surface sliding resistance for the safety devices.
Taping low friction sheet (such as super-high-molecular polyethylene sheet) to the all-contact face reduces the dust from abrasion and longer operating life is expected.
2. As for long stroke, Plarailchain is affected by the cables, etc. inside and might cause twist. Therefore, please insert cables with no winding or twisting.
3. The cables inside are easy to tangle for long stroke use. As such, please use divider or rack to divide room inside in order to avoid spiral twist of tubings/cables.
4. Long stroke or multiple movement operation cause accident such as protrusion of cables from middle part of Plarailchain due to pull-in effect. In order to prevent this, please fix cables firmly at the outlet of Plarailchain.
5. In the case of special operations, installation of safety device such as guide-rail may differ depending on the specification, please contact PISCO for details.



Safety Instructions

- This Safety Instructions aim to prevent personal injury and damage to properties by requiring proper use of PISCO products.

Be certain to follow ISO 4414 and JIS B 8370.

ISO 4414: Pneumatic fluid power ... Recommendations for the application of equipment to transmission and control systems.

JIS B 8370: General rules and safety requirements for systems and their components.

This Safety instructions are classified into "Danger", "Warning" and "Caution", depending on the degree of danger or damages caused by improper use of PISCO products.

 **Danger** : Hazardous conditions. It can cause death or serious personal injury.

 **Warning** : Hazardous conditions depending on usages. Improper Use of PISCO products can case death or serious personal injury.

 **Caution** : Hazardous conditions depending on usages. Improper use of PISCO products can cause personal injury or damages to properties.

 **Warning** : 1. Selection of pneumatic products.

(1) A user who is a pneumatic system designer or has sufficient experience and technical expertise should select PISCO products.

(2) Due to wide variety of operating conditions and applications for PISCO products, carry out the analysis and evaluation on PISCO products. The pneumatic system designer is solely responsible for assuring that the user's requirements are met and that the application presents no health or safety hazards. All designers are required to fully understand the specifications of PISCO products and constitute all systems based on the latest catalog or information, considering any malfunction.

2. Handle pneumatic equipment with enough knowledge and experience.

(1) Improper use of compressed air is dangerous. Assembly, operation and maintenance of machines using pneumatic equipment should be conducted by a person with enough knowledge and experience.

3. Do not operate machine / equipment or remove pneumatic equipment until safety is confirmed.

(1) Make sure that preventive measures against falling work-pieces or sudden movements of machine are completed before inspection or maintenance of these machine.

(2) When removing the pneumatic equipment, make sure that the above preventive measures are completed. A compressed air supply and the power supply to the machine must be off, and also the compressed air in the systems must be exhausted.

(3) Restart the machines with care after ensuring to take all preventive measures against sudden movements.

* Safety Instructions are subject to change without notice.



Common Safety Instructions for Products in This Catalog

□ PISCO products are designed and manufactured for use in general industrial machinery and equipment. Be sure to read and follow the instructions below:

⚠ Danger : 1. Do not use PISCO products for the following applications:

- Equipment used for maintaining / handling human life and body.
- Equipment used for moving / transporting human.
- Equipment specifically used for safety purposes.

⚠ Warning : 1. Do not use PISCO products under the following conditions.

- (1) Beyond the specifications or conditions stated in the catalog or the instructions.
- (2) Under the direct sunlight or outdoors.
- (3) Excessive vibrations and impacts.
- (4) Exposure / adhere to corrosive gas, inflammable gas, chemicals, seawater, water and vapor.*

* Some products can be used under the condition above (4). Refer to the details of specification and condition of each product.

2. Do not disassemble or modify PISCO products, which affect the performance, function, and basic structure of the product.
3. Do not touch the release-ring of push-in fitting when there is a working pressure. The lock may be released by the physical contact, and tube may fly out or slip out.
4. Frequent switchover of compressed air may generate heat, and there is a risk of causing burn injury.
5. Avoid any load on PISCO products, such as a tensile strength, twisting and bending. Otherwise there is a risk of causing damage to the products.
6. As for applications where threads or tubes swing / rotate, use Rotary Joints, High Rotary Joints or Multi-Circuit Rotary Block only. The other PISCO products can be damaged in these applications.
7. Use only Die Temperature Control Fitting Series, Tube Fitting Stainless SUS316 Series, Tube Fitting Stainless SUS316 Compression Fitting Series or Tube Fitting Brass Series under the condition of over 60°C (140°F) water or heat medium oil. Other PISCO products can be damaged by head and hydrolysis under the condition above.
8. As for the condition required to dissipate static electricity or provide an antistatic performance, use EG Series fitting and antistatic products only, and do not use other PISCO products. There is a risk that static electricity can cause system defects or failures.
9. Use only Fittings with a characteristic of spatter-proof such as Anti-spatter or Brass Series in a place where flame and weld spatter is produced. There is a risk of causing fire by sparks.
10. Turn off the power supply to PISCO products, and make sure there is no residual air pressure in the pipes and equipment before maintenance. Follow the instructions below in order to ensure safety.
 - (1) Make sure the safety of all systems related to PISCO products before maintenance.
 - (2) Restart of operation after maintenance shall be proceeded with care after ensuring safety of the system by preventive measures against unexpected moments of machines and devices where pneumatic equipment is used.
 - (3) Keep enough space for maintenance when designing a circuit.
11. Take safety measures such as providing a protection cover if there is a risk of causing damaged or fires on machine / facilities by a fluid leakage.

⚠ Caution : 1. Remove dusts or drain before piping. They may get into the peripheral machine / facilities and cause malfunction.

2. When inserting an ultra-soft tube into push-in fitting, make sure to place an Insert Ring into the tube edge. There is a risk of causing the escape of tube and a fluid leakage without using an Insert Ring.
3. The product incorporating NBR as seal rubber material has a risk of malfunction caused by ozone crack. Ozone exists in high concentrations in static elimination air, clean-room, and near the high-voltage motors, etc. As a countermeasure, material change from NBR to HNBR or FKM is necessary. Consult with PISCO for more information.
4. Special option "Oil-free" products may cause a very small amount of a fluid leakage. When a fluid medium is liquid or the products are required to be used in harsh environments, contact us for further information.
5. In case of using non-PISCO brand tubes, make sure the tolerance of the outer tube diameter and tube hardness are within the limits of Table 1.

Table 1. Tube O.D. Tolerance

mm size	Nylon tube (SHORE D63)	Polyurethane tube (SHORE A98)	inch size	Nylon tube (SHORE D63)	Polyurethane tube (SHORE A98)
ø1.8mm	-	±0.05mm	ø1/8	±0.1mm	±0.15mm
ø2mm	-	±0.05mm	ø5/32	±0.1mm	±0.15mm
ø3mm	-	±0.15mm	ø3/16	±0.1mm	±0.15mm
ø4mm	±0.1mm	±0.15mm	ø1/4	±0.1mm	±0.15mm
ø6mm	±0.1mm	±0.15mm	ø5/16	±0.1mm	±0.15mm
ø8mm	±0.1mm	±0.15mm	ø3/8	±0.1mm	±0.15mm
ø10mm	±0.1mm	±0.15mm	ø1/2	±0.1mm	±0.15mm
ø12mm	±0.1mm	±0.15mm	ø5/8	±0.1mm	±0.15mm
ø16mm	±0.1mm	±0.15mm			

6. Instructions for Tube Insertion

- (1) Make sure that the cut end surface of the tube is at a right angle without a scratch on the tube surface or deformations.
- (2) When inserting a tube, the tube needs to be inserted fully into the push-in fitting until the tubing edge touches the tube end of the fitting as shown in the figure below. Otherwise, there is a risk of leakage.
- (3) After inserting the tube, make sure it is inserted properly and not to be disconnected by pulling it moderately.
 - * When inserting tubes, Lock-claws may be hardly visible in the hole, observed from the front face of the release-ring. But it does not mean the tube will surely escape. Major causes of the tube escape are the followings;
 - ① Shear drop of the lock-claws edge
 - ② The problem of tube diameter (usually small)

Therefore, follow the above instructions from (1) to (3), even lock-claws is hardly visible

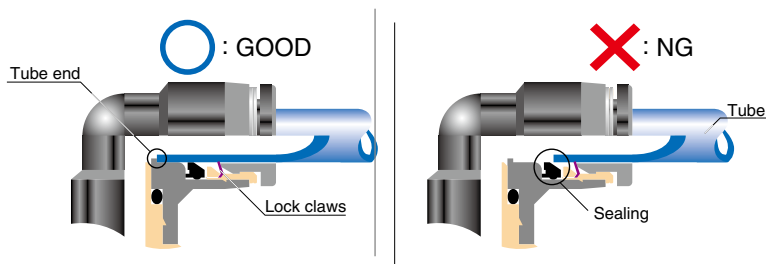

7. Instructions for Tube Disconnection

- (1) Make sure there is no air pressure inside of the tube, before disconnecting it.
- (2) Push the release-ring of the push-in fitting evenly and deeply enough to pull out the tube toward oneself. By insufficient pushing of the release-ring, the tube may not be pulled out or damaged by scratch, and tube shavings may remain inside of the fitting, which may cause the leakage later.

8. Instructions for Installing a fitting

- (1) When installing a fitting, use proper tools to tighten a hexagonal-column or inner hexagonal socket. When inserting a hex key into the inner hexagonal socket of the fitting, be careful so that the tool does not touch lock-claws. The deformation of lock-claws may result in a poor performance of systems or an escape of the tube.
- (2) Refer to Table 2 which shows the tightening torque. Do not exceed these limits to tighten a thread. Excessive tightening may break the thread part or deform the gasket to cause a fluid leakage. Tightening thread with tightening torque lower than these limits may cause a loosened thread or a fluid leakage. Since the sealability is affected by the processing condition of the installing part, adjust the tightening torque or correct the installing part, according to the condition.
- (3) Adjust the tube direction while tightening thread within these limits, since some PISCO products are not rotatable after the installation.

Table 2. Tightening Torque, Sealock Color and Gasket Material

Thread type	Thread size	Tightening torque	Sealock color	Gasket materials
Metric thread	M3×0.5	0.7N·m (0.52lbf·ft)	n/a	SPCC+NBR SUS304+NBR
	M5×0.8	1.0 ~ 1.5N·m (0.74 ~ 1.11lbf·ft)		
	M6×1.0	2.0 ~ 2.7N·m (1.48 ~ 1.99lbf·ft)		
	M3×0.5	0.7N·m (0.52 lbf·ft)		POM (Polyacetal)
	M5×0.8	1.0 ~ 1.5N·m (0.74 ~ 1.11lbf·ft)		
	M6×0.75	0.8 ~ 1.0N·m (0.59 ~ 0.74lbf·ft)		
Taper pipe thread	M8×0.75	1.0 ~ 2.0N·m (0.74 ~ 1.48lbf·ft)	White	n/a
	R1/8	4.5 ~ 6.5N·m (3.32 ~ 4.79lbf·ft)		
	R1/4	7 ~ 9N·m (5.16 ~ 6.64lbf·ft)		
	R3/8	12.5 ~ 14.5N·m (9.22 ~ 10.70lbf·ft)		
Unified thread	R1/2	20 ~ 22N·m (14.75 ~ 16.23lbf·ft)	n/a	SPCC+NBR, SUS304+NBR
	No. 10-32UNF	1.0 ~ 1.5N·m (0.74 ~ 1.11lbf·ft)		
National Pipe Thread Taper (American standard)	1/16-27NPT	4.5 ~ 6.5N·m (3.32 ~ 4.79lbf·ft)	White	n/a
	1/8-27NPT	4.5 ~ 6.5N·m (3.32 ~ 4.79lbf·ft)		
	1/4-18NPT	7 ~ 9N·m (5.16 ~ 6.64lbf·ft)		
	3/8-18NPT	12.5 ~ 14.5N·m (9.22 ~ 10.70lbf·ft)		
	1/2-14NPT	20 ~ 22N·m (14.75 ~ 16.23lbf·ft)		

* These values may differ for some products. Refer to each specification as well.



Tightening torque for silencer

Thread Type	Thread Size	Tightening Torque
Metric thread	M5×0.8	1/6 turn after hand-tightening
	M6×1.0	
	M10×1.0	
Parallel pipe thread	G1/8	1/2 ~ 1 turn after hand-tightening
	G1/4	
	G3/8	
	G1/2	

9. Instructions for removing a fitting

(1) When removing a fitting, use proper tools to loosen a hexagonal-column or an inner hex hexagonal socket. When inserting a hex key into the inner hex hexagonal socket of the fitting, be careful so that the tool does not touch lock-claws. The deformation of lock-claws may result in a poor performance of systems or an escape of the tube.

(2) Remove the sealant stuck on the mating equipment. The remained sealant may get into the peripheral equipment and cause malfunctions.

10. Arrange piping avoiding any load on fittings and tubes such as twist, tensile, moment load, shaking and physical impact. These may cause damages to fittings, tube deformations, bursting and the escape of tubes.

11. Impact caused by dropping or the like may lead to damage to the product and a fluid leakage.