

Terminal for USB2.0
High-Resolution Analog Input
AI-1608AY-USB



* Specifications, color and design of the products are subject to change without notice.

Features

Conversion speed 10μsec/ch, 16bit resolution, analog input 8ch
Equipped with the analog input (10μsec/ch, 16bit, 8ch) and digital I/O (4ch each, LVTTTL level)

Compatible to USB1.1/USB2.0 and not necessary to power this product externally as the bus power is used.

Compatible to USB1.1/USB2.0 and capable to achieve high speed transfer at HighSpeed (480 Mbps). Not necessary to power this product externally as the bus power of USB is used.

Sampling can be driven by a clock or by various triggers

Sampling can be started and stopped by software or by an external trigger (timing controlled by an externally input control signal).

The sampling period can be controlled by the internal clock (high-precision timer included on the board) or by an external clock (externally input control signal).

Windows/Linux compatible driver libraries are supported.

Using the analog I/O driver makes it possible to create applications of Windows/Linux. In addition, a diagnostic program by which the operations of hardware can be checked is provided.

Easy-to-wire terminal connector adopted

Adoption of terminal connector (with screws) enables to achieve easy wiring.

Software-based calibration function

Calibration of analog input can be all performed by software. Apart from the adjustment information prepared before shipment, additional adjustment information can be stored according to the use environment.

MATLAB and LabVIEW is supported by a plug-in of dedicated library.

Using the dedicated library makes it possible to create each application for MATLAB and LabVIEW.

This product is a USB2.0 compatible terminal module that extends the analog I/O function of USB port of PCs. 8ch/16bits analog inputs are employed and signal lines can be directly connected to the screw terminals in the system. Compact design to match Note PCs and excellent in mobility as operation is powered by USB bus. Windows/Linux driver and full-scale data logger software C-LOGGER are available.

- * The contents in this document are subject to change without notice.
- * Visit the CONTEC website to check the latest details in the document.
- * The information in the data sheets is as of February 2023.

Specifications

Item	Specification
Analog input	
Isolated specification	Un-Isolated
Input type	Single-Ended Input
Number of input channels	8ch
Input range	Bipolar ±10V
Maximum input rating	±20V
Input impedance	1MΩ or more
Resolution	16bit
Non-Linearity error *7	±12LSB
Conversion speed	10μsec/ch(Max) *1
Buffer memory	1K data *6
Conversion start trigger	Software / external trigger
Conversion stop trigger	Number of sampling times / external trigger/software
External start signal	LVTTTL level (Selecting one of the rising / falling / signal edge input to the DI00-pin by the software)
External stop signal	LVTTTL level (Selecting one of the rising / falling / signal edge input to the DI01-pin by the software)
External clock signal	LVTTTL level (Selecting the rising / falling to the DI02-pin by the software)
Digital I/O	
Number of input channels	Un-Isolated input 4ch (LVTTTL positive logic) *2*3
Number of output channels	Un-Isolated output 4ch (LVTTTL positive logic)
USB	
Bus specification	USB Specification 2.0/1.1 standard
USB transfer rate	12Mbps (Full-speed), 480Mbps (High-speed) *4
Power supply	Bus power
Common section	
Connector	14 pin (screw-terminal) plug header
Number of terminals used at the same time	127 terminals (Max) *5
Power consumption (Max)	5VDC 350mA
Operating condition	0 - 50°C, 10 - 90%RH(No condensation)
Physical dimensions(mm)	64(W) x 62(D) x 24(H) (exclusive of protrusions)
Weight	90g (Not including the USB cable, attachment)
Attached cable	USB cable 1.8m
Compatible wires	AWG28 - 16
Certification	FCC Class A, VCCI Class A, CE Marking (EMC Directive Class A, RoHS Directive), UKCA

- *1 Conversion speed for the A/D converter. The minimum executable sampling cycle depends on the operating condition of the terminal.
- *2 You cannot use both the DI00 / DI01 / DI02-pin of digital input feature and the external start / stop signal / external clock input simultaneously.
- *3 Each input accepts TTL (5VDC) level signals.
- *4 The USB transfer speed depends on the host PC environment used (OS and USB host controller).
- *5 As a USB hub is also counted as one device, you cannot just connect 127 USB terminals.
- *6 1K Word (1024 data) of buffer memory are implemented.
If (the number of channels) x (the number of samples) ≤ 1024 data, a sampling with a A/D converter's conversion rate of 10μSEC/ch is available. However, the actual amount of data that can be stored in the buffer memory will decrease: one unit of data of the buffer memory is consumed per sampling as the internal status.

The following is an image of the buffer memory:

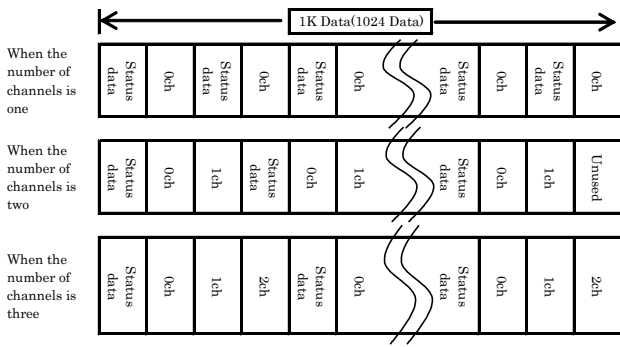

Consequently, the relationship among the number of channels, the number of samplings, and the sampling clock that can be sampled as described in the specification of the hardware is as follows:

Sampling channel	number of channel	number of sampling	Sampling clock
0ch	1	512	10μsec
0-1ch	2	341	20μsec
0-2ch	3	256	30μsec
0-3ch	4	204	40μsec
0-4ch	5	170	50μsec
0-5ch	6	146	60μsec
0-6ch	7	128	70μsec
0-7ch	8	113	80μsec

In the driver data software, the buffer memory is expanded to a 256 x 1024 data. However, if the number of samplings that exceeds the table above is specified, an adjustment of the sampling clock is required for the data transfer process from the device to the PC, which may prevent a sampling with the sampling clock above.

*7 When the ambient temperature is 0°C or 50°C, a non-linearity error (about 0.1% of the maximum range) may occur. When a signal source with a built-in high-speed operational amplifier is used.

Support Software

Driver Library API-AIO(WDM)

The API-AIO(WDM) is the Windows version driver library software that provides products in the form of Win32 API functions (DLL). Various sample programs such as Visual Basic and Visual C++, etc and diagnostic program *1useful for checking operation is provided.

Data Logger Software C-LOGGER

C-LOGGER is a data logger software program compatible with our analog input products. This program enables the graph display of recorded signal data, zoom observation, file saving, and dynamic transfer to the spreadsheet software "Excel". No troublesome programming is required.

For details on the supported operating systems and applicable languages and to download the latest version, see the services on the CONTEC website

LabVIEW VI Library for Data Acquisition DAQfast for LabVIEW

This is a data collection library to use our devices in the LabVIEW by National Instruments. With Polymorphic VI, our design enables a LabVIEW user to operate seamlessly. Our aim is for the customers to perform easily, promptly what they wish to do.

For more details on the library and download of DAQfast for LabVIEW, please visit the CONTEC's Web site.

Data Acquisition library for MATLAB ML-DAQ

This is the library software which allows you to use our analog I/O device products on MATLAB by the MathWorks. Each function is offered in accordance with the interface which is integrated in MATLAB's Data Acquisition Toolbox.

For more details on the library and download, please visit the CONTEC's Web site.

Data acquisition VI library for LabVIEW VI-DAQ

This is a VI library to use in National Instruments LabVIEW. VI-DAQ is created with a function form similar to that of LabVIEW's Data Acquisition VI, allowing you to use various devices without complicated settings.

For more details on the library and download, please visit the CONTEC's Web site.

Cable & Connector

14pin Screw Terminal Connector Set(6 pieces) : CN6-Y14

Accessories

Bracket for USB I/O Terminal products : BRK-USB-Y

* Check the CONTEC's Web site for more information on these options.

Packing List

USB terminal [AI-1608AY-USB]...1

Interface connector plugs...2

Please read the following...1

USB Cable(1.8m)...1

USB Cable Attachment...1

Block Diagram

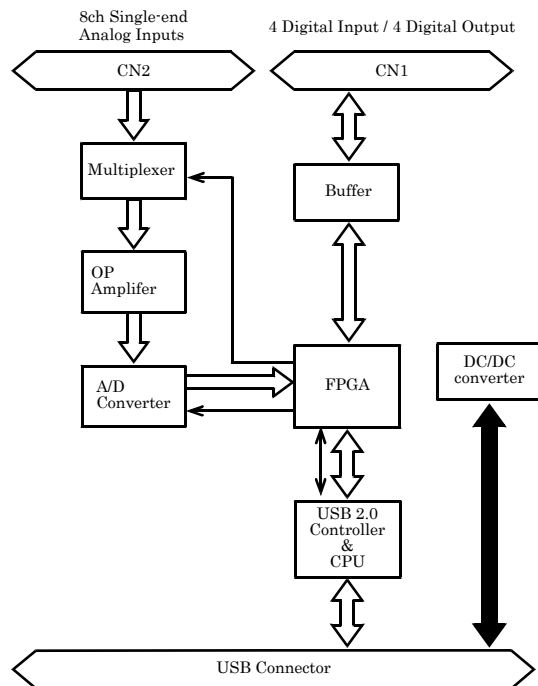

Physical Dimensions

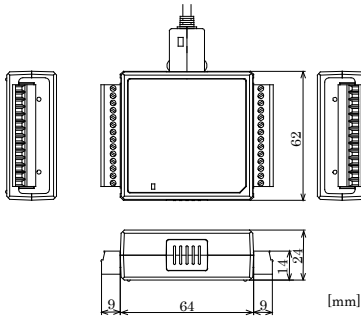

Cable connection

When connecting the product to an external device, you can use the supplied connector plug.

For wiring, strip off approximately 9 - 10mm of the covered part of a wire rod and then insert it to the opening. After the insertion, secure the wire rod with screws. Compatible wires are AWG 28 - 16.

CAUTION

Removing the connector plug by grasping the cable can break the wire.

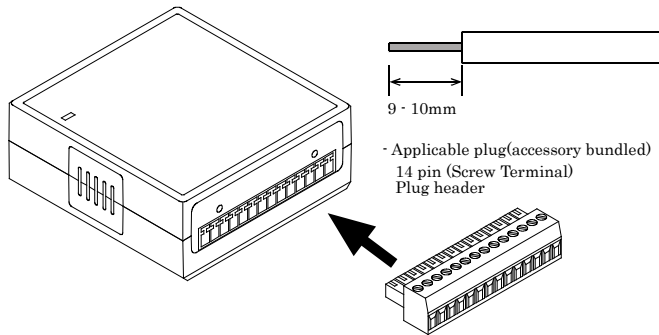

Using the On-terminal Connectors

Connecting a terminal to a Connector

To connect an external device to this terminal, plug the cable from the device into the interface connector (CN1, CN2) shown below.

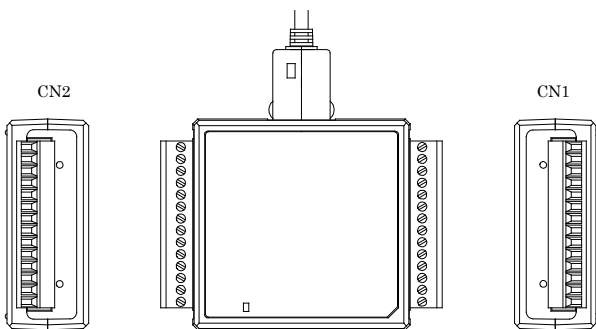

Connector Pin Assignment

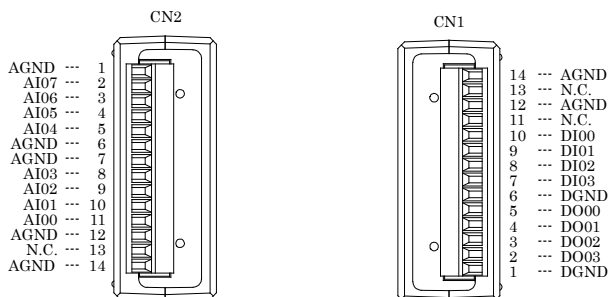

AI00 - AI07	Analog input signal. The numbers correspond to channel numbers.
AGND	Common analog ground for analog input signals.
DI00 - DI03	Digital input signal.
DO00 - DO03	Digital output signal.
DGND	Common digital ground for digital I/O signals

Analog Input Signal Connection

Analog signal input types are divided into single-ended input and differential input. This product uses single-ended input fixed. The following examples show how to connect analog input signals using a flat cable and a shielded cable.

Single-ended Input Connection (Flat Cable)

The following figure shows an example of flat cable connection. Connect separate signal and ground wires for each analog input channel on CN1.

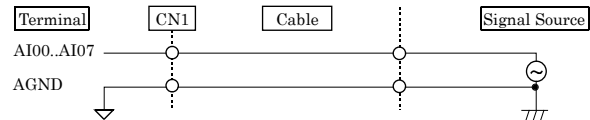

Single-ended Input Connection (Shielded Cable)

The following figure shows an example of shield cable connection. Use shielded cable if the distance between the signal source and product is long or if you want to provide better protection from noise. For each analog input channel, connect the core wire to the signal line and connect the shielding to ground.

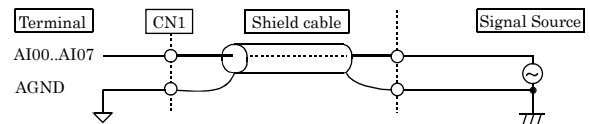

CAUTION

- If the signal source contains over 1MHz signals, the signal may effect the cross-talk noise between channels.
- If the product and the signal source receive noise or the distance between the product and the signal source is too long, data may not be input properly.
- An input analog signal should not exceed the maximum input voltage (relate to the product analog ground). If it exceeds the maximum voltage, the product may be damaged.
- Connect all the unused analog input channels to analog ground.
- The signal connected to an input channel may fluctuate after switching of the multiplexer. In this case, the cable between this product and the signal source can be shortened or a buffer with a high-speed amplifier can be placed between the product and the signal source in order to reduce the fluctuation.

Digital I/O signals Connection

The digital I/O signal can be used as the control signal (external trigger input signal and sampling clock input signal, etc.), too. The following sections show examples. All the digital I/O signals are LVTTTL (3.3VDC) level signals.

Digital Input Connection

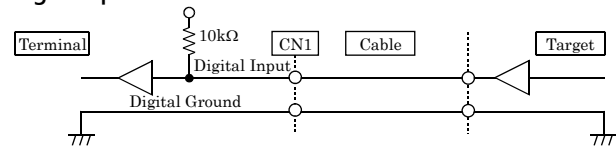

Digital Output Connection

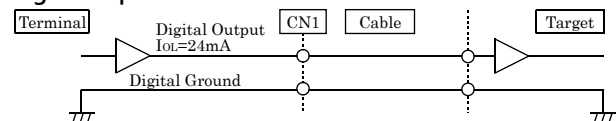

CAUTION

Do not short the output signals to analog ground, digital ground, and/or power line. Doing so may damage the terminal. Each input accepts TTL(5VDC) level signals.

Reference

For the operation timing when using it as control signal, see manual.