

Terminal for USB2.0  
High-Resolution Analog I/O  
**AIO-160802GY-USB**



\* Specifications, color and design of the products are subject to change without notice.

## Features

### Input 4 $\mu$ sec/ch, 8ch, output 10 $\mu$ sec, 2ch, 16bit resolution

Equipped with the analog input (4 $\mu$ sec/ch, 16bit, 8ch) and digital I/O (4ch each, LVTTTL level)

### Compatible to USB1.1/USB2.0 and not necessary to power this product externally as the bus power is used.

Compatible to USB1.1/USB2.0 and capable to achieve high speed transfer at HighSpeed (480 Mbps). Not necessary to power this product externally as the bus power of USB is used.

### Equipped with the buffer memory which can be used in either FIFO or ring format

This product includes buffer memory (8K data for analog input and 1K data for output) which can be used in either FIFO or ring format. You can perform analog I/O in the background, independent of software and the current status of the PC.

### Windows compatible driver libraries are attached.

Using the attached driver library API-USBP(WDM) makes it possible to create applications of Windows. In addition, a diagnostic program by which the operations of hardware can be checked is provided.

### Supported to the data logger software [C-LOGGER]

Supporting the data logger software [C-LOGGER] that enables the graph display of recorded signal data, file saving, and dynamic transfer to the spreadsheet software program "Excel".

### Sampling can be driven by a clock or by various triggers

Sampling can be started and stopped by software or by an external trigger (timing controlled by an externally input control signal).

The sampling period can be controlled by the internal clock (high-precision timer included on the board) or by an external clock (externally input control signal).

### Terminal connector facilitating wiring

Wiring is easy as the terminal connector (screw type) is used.

### Software-based calibration function

Calibration of analog input/output can be all performed by software. Apart from the adjustment information prepared before shipment, additional adjustment information can be stored according to the use environment.

This product is a USB2.0 compatible terminal module that extends the analog I/O function of USB port of PCs. 8ch/16bits analog inputs and 2ch/16bits analog outputs are employed and signal lines can be directly connected to the screw terminals in the system. Compact design to match Note PCs and excellent in mobility as operation is powered by USB bus. This product accompanies Windows driver and full-fledged data logger software "C-LOGGER".

With plug-ins for the dedicated libraries, this product also supports LabVIEW.

- \* The contents in this document are subject to change without notice.
- \* Visit the CONTEC website to check the latest details in the document.
- \* The information in the data sheets is as of June 2022.

## Plug-ins for the dedicated libraries, this product also supports LabVIEW.

We offer a dedicated library [DAQfast for LabVIEW], which allows you to use the product on LabVIEW by National Instruments. These dedicated libraries are available, free of charge (downloadable), on our web site.

## Support Software

### Windows version of analog I/O driver API-AIO(WDM)

The API-AIO(WDM) is the Windows version driver library software that provides products in the form of Win32 API functions (DLL). Various sample programs such as Visual Basic and Visual C++, etc and diagnostic program useful for checking operation is provided.

For more details on the supported OS, applicable language and new information, please visit the CONTEC's Web site.

### Data Logger Software C-LOGGER

C-LOGGER is a data logger software program compatible with our analog input products. This program enables the graph display of recorded signal data, zoom observation, file saving, and dynamic transfer to the spreadsheet software "Excel". No troublesome programming is required.

For details on the supported operating systems and applicable languages and to download the latest version, see the services on the CONTEC website

### LabVIEW VI Library for Data Acquisition DAQfast for LabVIEW

This is a data collection library to use our devices in the LabVIEW by National Instruments. With Polymorphic VI, our design enables a LabVIEW user to operate seamlessly. Our aim is for the customers to perform easily, promptly what they wish to do.

For more details on the library and download of DAQfast for LabVIEW, please visit the CONTEC's Web site.

## Specifications

Item	Specification
<b>Analog input</b>	
Isolated specification	Unisolated
Input type	Single-Ended Input
Number of input channels	8ch
Input range	Bipolar ±10V
Maximum input rating	±20V
Input impedance	1MΩ or more
Resolution	16bit
Non-Linearity error	±12LSB
Conversion speed	4μsec/ch (Max) *3
Buffer memory	8K data
Conversion start trigger	Software / external trigger
Conversion stop trigger	Number of sampling times / external trigger/software
External start signal	LVTTL level (Selecting the rising / falling edge to the DI00-pin by the software) *8
External stop signal	LVTTL level (Selecting the rising / falling edge to the DI01-pin by the software) *8
External clock signal	LVTTL level (Selecting the rising / falling edge to the DI02-pin by the software) *8
<b>Analog output</b>	
Isolated specification	Unisolated
Number of output channels	2ch
Output range	Bipolar ±10V
Absolute max. output current	±1mA
Output impedance	1Ω or less
Resolution	16bit
Non-Linearity error	±12LSB
Conversion speed	10μsec (Max) *3
Buffer memory	1K data
Conversion start trigger	Software / external trigger
Conversion stop trigger	Number of sampling times / external trigger/software
External start signal	LVTTL level (Selecting the rising / falling edge to the DI00-pin by the software) *8
External stop signal	LVTTL level (Selecting the rising / falling edge to the DI01-pin by the software) *8
External clock signal	LVTTL level (Selecting the rising / falling edge to the DI02-pin by the software) *8
<b>Digital I/O</b>	
Number of input channels	Unisolated input 4ch (LVTTL positive logic) *4*5
Number of output channels	Unisolated output 4ch (LVTTL positive logic)
<b>USB</b>	
Bus specification	USB Specification 2.0/1.1 standard
USB transfer rate	12Mbps (Full-speed), 480Mbps (High-speed) *6
Power supply	Bus power
<b>Common section</b>	
Connector	14 pin (screw-terminal) plug header
Number of terminals used at the same time	127 terminals (Max) *7
Power consumption (Max)	5VDC 470mA
Operating condition	0 - 50°C, 10 - 90%RH(No condensation)
Physical dimensions (mm)	64(W) x 62(D) x 24(H) (exclusive of protrusions)
Weight	90g (Not including the USB cable, attachment)
Attached cable	USB cable 1.8m
Compatible wires	AWG28 - 16
Standard	VCCI Class A, FCC Class A, CE Marking (EMC Directive Class A, RoHS Directive), UKCA

- \*1 The non-linearity error means an error of approximately 0.1% occurs over the maximum range at 0°C and 50°C ambient temperature.
- \*2 When using the signal source equipped with the high-speed operational amplifier
- \*3 This numerical displays the conversion speed for A/D, D/A converter. The minimum executable sampling cycle depends on the operating condition of the terminal.
- \*4 You cannot use both the DI00 / DI01 / DI02-pin of digital input feature and the external start / stop signal / external clock input simultaneously.
- \*5 Each input accept TTL (5VDC) level signals.
- \*6 The USB transfer speed depends on the host PC environment used (OS and USB host controller).
- \*7 As a USB hub is also counted as one device, you cannot just connect 127 USB terminals.
- \*8 The analog input / output are shared, so cannot trigger set different trigger settings for the same terminal.

## Cable & Connector

14pin Screw Terminal Connector Set(6 pieces) : CN6-Y14

## Accessories

Bracket for USB I/O Terminal products : BRK-USB-Y

\* Check the CONTEC's Web site for more information on these options.

## Packing List

- USB terminal [AIO-160802GY-USB]...1
- Interface connector plugs...2
- First step guide...1
- Disk \*1 [API-USB(WDM)]...1
- USB Cable(1.8m)...1
- USB Cable Attachment...1
- Serial number label...1
- Product Registration Card & Warranty Certificate...1
- \*1 Driver software, User's Guide (this guide)

## Physical Dimensions

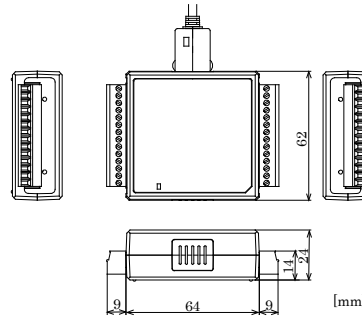

## Cable connection

When connecting the product to an external device, you can use the supplied connector plug.

For wiring, strip off approximately 9 - 10mm of the covered part of a wire rod and then insert it to the opening. After the insertion, secure the wire rod with screws. Compatible wires are AWG 28 - 16.

### CAUTION

Removing the connector plug by grasping the cable can break the wire.

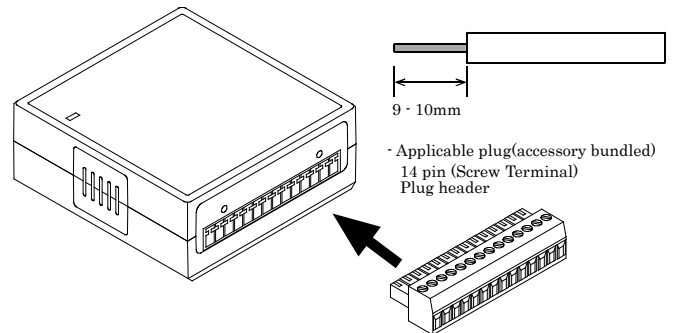

## Using the On-terminal Connectors

### Connecting a terminal to a Connector

To connect an external device to this terminal, plug the cable from the device into the interface connector (CN1, CN2) shown below.

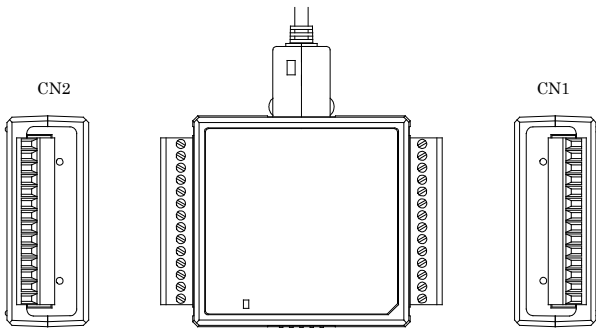

### Connector Pin Assignment

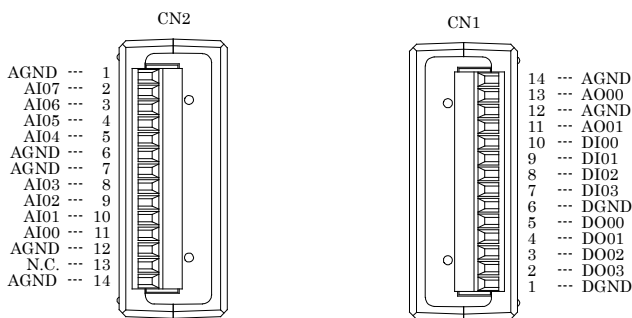

AI00 - AI07	Analog input signal. The numbers correspond to channel numbers.
AO00 - AO01	Analog output signal. The numbers correspond to channel numbers.
AGND	Common analog ground for analog I/O signals.
DI00 - DI03	Digital input signal.
DO00 - DO03	Digital output signal.
DGND	Common digital ground for digital I/O signals

## Analog Input Signal Connection

### Single-ended Input Connection (Flat Cable)

The following figure shows an example of flat cable connection. Connect separate signal and ground wires for each analog input channel on CN2.

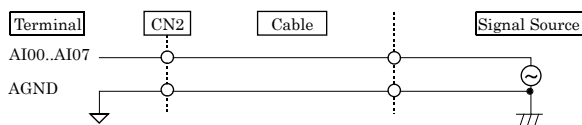

### Single-ended Input Connection (Shielded Cable)

The following figure shows an example of shielded cable connection. Use shielded cable if the distance between the signal source and product is long or if you want to provide better protection from noise. For each analog input channel, connect the core wire to the signal line and connect the shielding to ground.

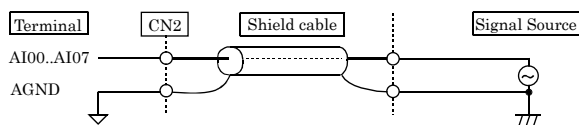

#### CAUTION

- If the signal source contains over 1MHz signals, the signal may effect the cross-talk noise between channels.
- If the product and the signal source receive noise or the distance between the product and the signal source is too long, data may not be input properly.
- An input analog signal should not exceed the maximum input voltage (relate to the product analog ground). If it exceeds the maximum voltage, the product may be damaged.
- Connect all the unused analog input channels to analog ground.
- The signal connected to an input channel may fluctuate after switching of the multiplexer. In this case, the cable between this product and the signal source can be shortened or a buffer with a high-speed amplifier can be placed between the product and the signal source in order to reduce the fluctuation.

## Analog Output Signal Connection

This section shows how to connect the analog output signal by using a flat cable or a shielded cable.

The following figure shows an example of flat cable connection. Connect the signal source and ground to the CN1 analog output.

### Analog Output Connection (Flat Cable)

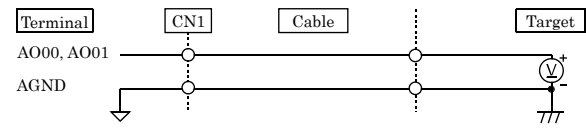

The following figure shows an example of shield cable connection. Use shielded cable if the distance between the signal source and product is long or if you want to provide better protection from noise. For each analog input channel on CN1, connect the core wire to the signal line and connect the shielding to ground.

### Analog Output Connection (Shielded Cable)

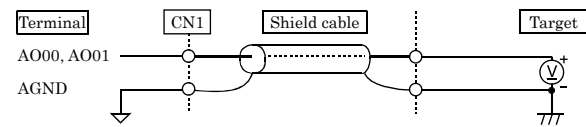

#### CAUTION

- If this product or the connected wire receives noise, or the distance between this product and the target is long, data may not be outputted properly.
- For analog output signal, the current capacity is ±1mA (Max). Check the specification of the connected device before connecting this product.
- Do not short the analog output signal to analog ground, digital ground, and/or power line. Doing so may damage this product.
- Do not connect an analog output signal to any other analog output, either on this product or on an external device, as this may cause a fault on this product.
- When the USB cable is plugged, the analog output signal will be -10V.

## Digital I/O signals Connection

The digital I/O signal can be used as the control signal (external trigger input signal and sampling clock input signal, etc.), too. The following sections show examples. All the digital I/O signals are LVTTTL (3.3VDC) level signals.

### Digital Input Connection

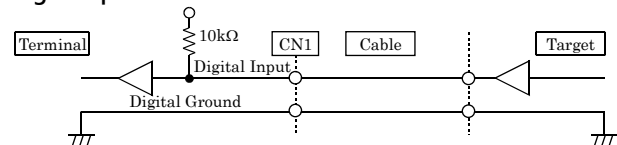

### Digital Output Connection

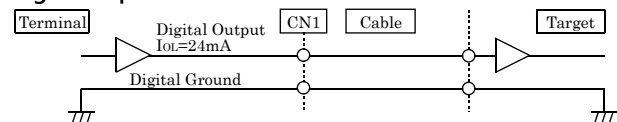

#### CAUTION

- Do not short the output signals to analog ground, digital ground, and/or power line. Doing so may damage the terminal.
- Each input accepts 5V TTL level signals.

### Reference

For the operation timing when using it as control signal, see "Control Signal Timings" in Chapter 7 "About Hardware - Control Signal Timings".

## Differences between AIO-160802AY-USB and AIO-160802GY

The connector pins of the AIO-160802GY-USB are compatible with those of the conventional AIO-160802AY-USB, but the following main differences exist.

	AIO-160802AY-USB	AI-160802GY-USB
Analog input conversion speed	10usec/ch	4usec/ch
Analog input buffer memory	1k data	8k data