

**CONPROSYS nano Series**  
**Thermocouple Module**  
**CPSN-SSI-4C**



This product is an expansion I/O module that adds a thermocouple interface to the CPU unit of the CONPROSYS nano series.

Four channels of differential inputs are provided for one module.

- \* Specifications, color and design of the products are subject to change without notice.
- \* The contents in this document are subject to change without notice.
- \* Visit the CONTEC website to check the latest details in the document.
- \* The information in the data sheets is as of July 2022.

**Features**

Compatible with various types of thermocouple inputs  
 This product is compatible with a wide range of thermocouple input types such as J(IEC60584-1), K(IEC60584-1), E(IEC60584-1), N(IEC60584-1), R(IEC60584-1), S(IEC60584-1), and T(IEC60584-1).

Cold junction compensation function within  
 As cold junction compensation is integrated in the product, there is no need to install a temperature sensor for cold junction compensation externally, and temperature can be measured simply by connecting a thermocouple.

LED indicator for status check  
 The error status of thermocouple such as disconnected, not-connected, or sensor circuit trouble can be checked with the LED indicator.

Easy installation and removal  
 This product can be installed in and removed from the CPU unit without any tools.

Adaptable to a wide range of temperature between -20 and +60°C  
 The product is capable of operating in the temperature between -20 and + 60°C. It can be installed in the various environments.

No electrolytic capacitor  
 Without an electrolytic capacitor, which has a limited life, we are creating the product with a longer life.

**List of Options**

- CPU unit  
 CPSN-MCB271-S1-041: Remote I/O Model CPU unit  
 CPSN-MCB271-1-041: Remote I/O CPU unit LAN 2-channel model  
 CPSN-PCB271-S1-041: CODESYS Modbus Master CPU unit
- DIN rail mounting power supply  
 CPS-PWD-30AW24-01: DIN rail mounting power supply 30[W]  
 Input: 100 - 240VAC, output: 24VDC 1.3 A)
- CPS-PWD-90AW24-01: DIN rail mounting power supply 90[W]  
 Input: 100 - 240VAC, output: 24VDC 3.8 A)

\* Visit the Contec website regarding information on the optional products.

**Specifications**

Function specifications

Item	CPSN-SSI-4C
Input type	Differential input
Input channel	4ch
Resolution	24-bit (1/1024 °C)
Conversion speed*1	251ms (Measure four thermocouples and one cold junction sensor per channel)
Buffer memory	The latest data only
Conversion start condition	Constant update
Compatible thermocouple sensor	J(IEC 60584-1), K(IEC 60584-1), E(IEC 60584-1), N(IEC 60584-1), R(IEC 60584-1), S(IEC 60584-1), T(IEC 60584-1)
Conversion tolerance	Thermocouple type K, J, E, N, T: Within ± [0.3°C + Measured temperature×0.12% (0°C or higher) or 1% (0°C or lower)] Thermocouple type R, S: Within ± [1.2°C + Measured temperature×0.12%]
Cold junction sensor	Integrated
Cold junction tolerance *2*3	Within 3.6°C (Vertical installation (Installation angle 0°))
Isolation	Bus isolation
Isolation withstand voltage	500VDC
Connector	2 pieces 3.81mm pitch 10-pin terminal
Applicable wire	AWG28 - 16
LED	4 (Green)
Electricity consumption	5V 0.15A (Max.) 3.3V 0.05A (Max.)
Physical dimensions (mm)	15.6(W)×52.6(D)×84(H) (No projection included)
Weight	50g

- \*1 It is the conversion time of the measurement value. Communication time is not included.
- \*2 It is the measured value under the condition of wind speed of 0-0.5m/s in the thermostatic bath.
- \*3 The cold junction tolerance is within 4.6 °C when the product is installed in the orientation other than vertical installation (Installation angle 0 °). Installation orientation requires software command to change the settings. (Default: vertical installation)

Installation Environment Requirements

Item		Description
Operating ambient temperature		-20 - +60°C (Wall installation at an angle of 0°) -20°C to +55°C with a vertical installation at an angle of 90° to the left/right or with a plane installation
Operating ambient humidity		10 - 90%RH (No condensation)
Non-operating ambient temperature		-20 - +60°C
Non-operating ambient humidity		10 - 90%RH (No condensation)
Floating dust particles		Not to be excessive
Corrosive gases		None
Line-noise resistance	Line noise	Signal Line /±1kV (IEC61000-4-4 Level 3, EN61000-4-4 Level 3)
	Static electricity resistance	Touch /±4kV (IEC61000-4-2 Level 2, EN61000-4-2 Level 2) Air /±8kV (IEC61000-4-2 Level 3, EN61000-4-2 Level 3)
Vibration resistance	Sweep resistance	10 - 57Hz *4 /semi-amplitude vibration 0.15mm, 57 - 150Hz/2.0G 40minutes each in X, Y, and Z directions (JIS C60068-2-6-compliant, IEC60068-2-6-compliant)
	Shock resistance	15G half-sine shock for 11ms in X, Y, and Z directions (JIS C 60068-2-27 -compliant, IEC 60068-2-27 -compliant)
Standard		VCCI Class A, FCC Class A, CE Marking (EMC Directive Class A, RoHS Directive), UKCA

\*4 With the optional DIN rail fitting power supply: 10 - 55Hz (for details, see the user's guide of the optional power supply).

Physical Dimensions

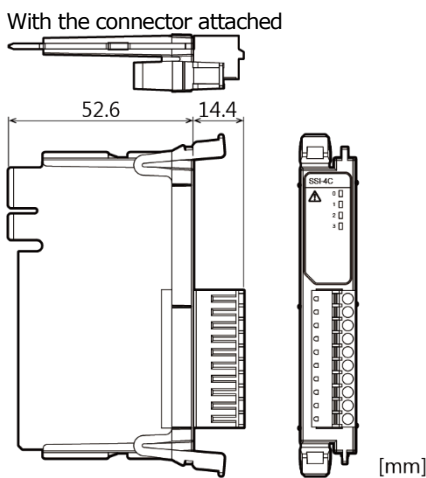
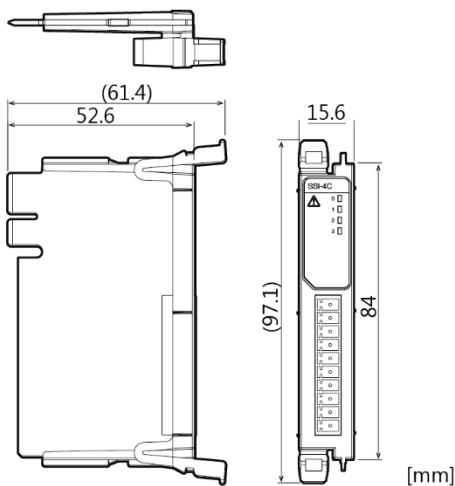

Packing List

- Product ...1
- 10-pin connector...1
- Product Guide & Warranty Certificate... 1
- Serial Number Label ...1

Name of each parts

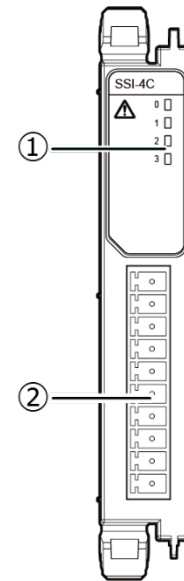

- (1) LED : This indicates status of the product.
- (2) Interface Connector : Connector for thermocouple measurement. Use the 10-pin connector included in the package.

Interface Connector

Four channels of thermocouple inputs are provided. Use the 10-pin connector included in the package.

Connector type : DEGSON 15EDGKC-3.81-10P-13 (or equivalent)

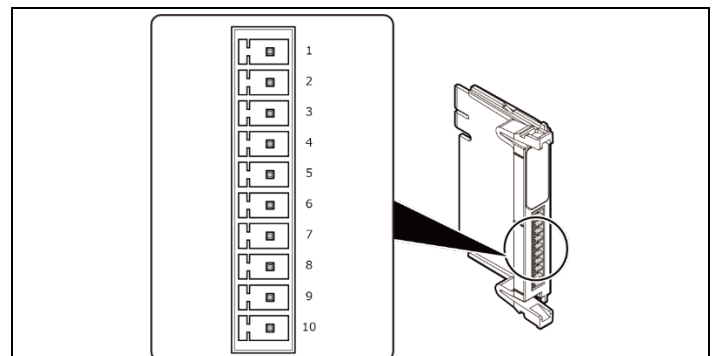

Pin No.	Signal Name	Meaning
1	TC0+	Thermocouple input terminal (positive side) of channel 0.
2	TC0-	Thermocouple input terminal (negative side) of channel 0.
3	TC1+	Thermocouple input terminal (positive side) of channel 1.
4	TC1-	Thermocouple input terminal (negative side) of channel 1.
5	AGND	This is an analog ground and shares channels of analog input signals.
6	TC2+	Thermocouple input terminal (positive side) of channel 1.
7	TC2-	Thermocouple input terminal (negative side) of channel 1.
8	TC3+	Thermocouple input terminal (positive side) of channel 3.
9	TC3-	Thermocouple input terminal (negative side) of channel 3.
10	AGND	This is an analog ground and shares channels of analog input signals.

Thermocouple Input Cable

Use the thermocouple input cable described below.

Cable	Thermocouple and compensating wire.
Applicable wire	AWG28 - 16
Cable Length	Vary according to the environment where the product is used.

## Thermocouple Input

Input type of thermocouple is differential input and four channels are provided for the product. Compatible thermocouples types are K, J, E, N, T, R, and S. Setting thermocouples type requires software command. (Default :K type)

The measuring temperature range per thermocouples type is listed below.

Even if the measuring temperature range is exceeded, it is possible to measure up to the measuring temperature limit, however the temperature tolerance may exceed the specified value.

### Measuring temperature range

Thermocouples type	Measuring temperature range
K	-100°C - 1372°C
J	-100°C - 1200°C
E	-100°C - 1000°C
N	-100°C - 1300°C
T	-100°C - 400°C
R	0°C - 1768°C
S	0°C - 1768°C

### Measuring temperature limit

Thermocouples type	Measuring temperature range	
	Lower-limit temperature	Upper-limit temperature
K	-265°C	1372°C
J	-210°C	1200°C
E	-265°C	1000°C
N	-265°C	1300°C
T	-265°C	400°C
R	-50°C	1768°C
S	-50°C	1768°C

### CAUTION

- When adjusting the temperature with such as an air conditioner, take measures to prevent the product from being exposed directly to the air.
- Right after the product is started, the measuring temperature may exceed the specified tolerance. Warm up the product for at least 30 minutes before use.

### Example of thermocouple connection

The following figure shows an example of thermocouple connection. Connect the positive and negative terminals of each thermocouple to the positive and negative sides of each thermocouple input channel.

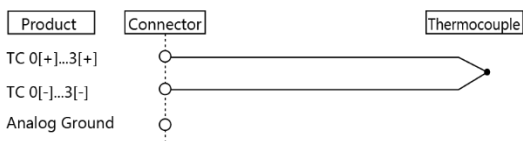

### Example of shielded thermocouple connection

The following figure shows an example of shielded thermocouple connection. Use shielded thermocouple cable if the distance between the temperature measuring place and the product is long or if you want to provide better protection from noise. Connect the positive and negative terminals of each thermocouple to the positive and negative sides of each thermocouple input channel. Then, connect the analog ground of this product to the shielded braid and earth ground the shielded braid.

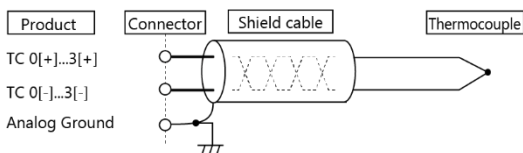

### CAUTION

- When using the product in an overly noisy environment, use a shielded thermocouple and earth ground the shield.