

10MSPS 12-bit Analog Input Board for PCI Express AI-1204Z-PE



* Specifications, color and design of the products are subject to change without notice.

Features

Maximum conversion speed is 10MSPS (100nsec), with simultaneous sampling of 4channels at a time
The maximum conversion speed is 10MSPS (100nsec) and 4channels can be sampled simultaneously.

The range for each channel can be set independently by software to match the level of the input signal source.
(Input range : $\pm 10V$, $\pm 5V$, $\pm 2.5V$, $\pm 1.25V$ or 0 - $+10V$, 0 - $+5V$, 0 - $+2.5V$)

Also features digital inputs and outputs (four LVTTTL level input and output ports respectively).(requires the optional DT-E3 cable)

Sampling can be controlled by software, conversion data comparison, external trigger, event controller output, and similar start and stop conditions
Sampling can be setup to be started and stopped by software, conversion data comparison, external trigger, or event controller output.
Control of sampling start and stop is completely independent and a separate setting is provided for each. It is also possible to specify that sampling stop after a specified number of samples. The conversion data comparison function can perform level, in-range, and out-of-range comparisons on the conversion data.

Incorporates a synchronization control connector for synchronized operation
A synchronization control connector is provided for synchronized control of up to 16 boards. This means the number of channels can be increased simply by adding boards. It is also easy to synchronize operation with other CONTEC boards that have a synchronization control connector.

Bus master transfer function allows continuous data acquisition at high speed for a long period
The bus master transfer function allows continuous data acquisition to be performed at high speed for a long period. Furthermore, this function can transfer large volumes of data between the board and the PC.

BNC connector used for analog input pin
The BNC connector used for the analog input has a characteristic impedance of 50Ω and is of a type commonly used for high speed analog signals. This makes it easy to connect to other devices with a BNC connector.

This product is a PCI Express bus-compliant interface board used to provide an analog signal input function on a PC. Maximum conversion speed is 10MSPS (100nsec), with simultaneous sampling of four channels at a same time. The bus master transfer function allow continuous data acquisition to be performed at high speed for a long period. Sampling can be started and stopped by software, conversion data comparison (level comparison, in-range comparison, out-of-range comparison), external trigger, or event controller output. Uses a BNC connector that can connect directly to the signal source.
Also features four digital input and output ports respectively (requires the optional DT-E3 cable).

* The contents in this document are subject to change without notice.
* Visit the CONTEC website to check the latest details in the document.
* The information in the data sheets is as of June 2022.

Termination resistor selection function

A 50Ω termination resistor can be set to minimize the distortion caused by the reflection of high-speed input signals. The input range cannot be set to $\pm 10V$ or 0 to $+10V$ when the termination resistor is used.

Digital filter function included to prevent misdetection due to chattering on external input signals
A digital filter is included to prevent misdetection due to chattering on the digital input signals.

Software-based calibration function
Calibration of analog input can be all performed by software. Apart from the adjustment information prepared before shipment, additional adjustment information can be stored according to the use environment.

Windows compatible driver software is provided
Using the driver software API-AIO(WDM), which can be downloaded from the CONTEC website, makes it possible to create applications of Windows. In addition, a Diagnostic Program to confirm the hardware operations is included in the software as well.

Functions and connectors are compatible with PCI compatible board AI-1204Z-PCI
The functions same with PCI compatible board AI-1204Z-PCI is provided. In addition, as there is compatibility in terms of connector shape and pin assignments, it is easy to migrate from the existing system.

Packing List

Product...1
Setup Guide...1
Warranty Certificate...1
Serial Number Label...1
Synchronization Control Cable...1

Specification

Function specifications

Item	AI-1204ZPE	
Analog input	Isolated specification	Unisolated
	Input type	Single-Ended Input
	Input channel	4ch
	Input range	(When 50Ω termination setting disabled) Bipolar ±10V, ±5V, ±2.5V, ±1.25V or Unipolar 0 - +10V, 0 - +5V, 0 - +2.5V (When 50Ω termination setting enabled) Bipolar ±5V, ±2.5V, ±1.25V or Unipolar 0 - +5V, 0 - +2.5V
	Maximum input voltage *1	(When 50Ω termination setting disabled) When the power is ON ±13V (Max.) When the power is OFF ±13V (Max.) (When 50Ω termination setting enabled) When the power is ON ±7V (Max.) When the power is OFF ±7V (Max.)
	Input impedance	1MΩ or more 50Ω±1%(when 50Ω termination setting enabled)
	Resolution	12bit
	Conversion accuracy *2*4	Within ±4LSB (input range : ±10V) Within ±6LSB (input range : 0 - +10V, ±5V) Within ±8LSB (input range : 0 - +5V, ±2.5V) Within ±10LSB (input range : 0 - +2.5V, ±1.25V)
	Non-linear error *2*3*4	±3LSB
	Conversion speed	100nsec (Max.)
	Passband (-3dB)	10MHz
	Buffer memory	1G data (Max.) *5
	Conversion start trigger	Software, conversion data compare, external trigger, and event controller output.
	Conversion stop trigger	Settings include data save complete, conversion data compare, external trigger, event controller output, and software.
	External start signal	LVTTL level (Rising or falling edge can be selected by software)
	External stop signal	LVTTL level (Rising or falling edge can be selected by software)
	External clock signal	LVTTL level (Rising or falling edge can be selected by software)
	External status output signal	LVTTL level Sampling clock output
Digital input	Number of input channels	4ch
	Input type	Unisolated input (LVTTL level positive logic)
Digital output	Number of output channels	4ch
	Output format	Unisolated output (LVTTL level positive logic)
Bus master section	DMA channels	1ch
	Transfer bus width	64/32bit
	Transfer rate	360MByte/s
Synchronization bus section	Control output signal	Selection of output signal with the software when specifying a sync master board.
	Control input signal	Selection of sync factor with the software when specifying sync slave boards.
	Max. board count for connection	16 boards including the master board
Common section	Memory addresses	Occupies 2 locations 256MByte
	Connector used	For analog (CN1,2,3,4) : BNC connector B-901W1AAN03 equivalent [mfd. By INSERT ENTERPRISE]. For digital (CN5) : 16pin pin header connector
	Current consumption (Max.)	5VDC 1600mA, 12V 550mA
	Operating condition	0 - 50°C, 10 - 90%RH (No condensation)
	Bus specification	PCI Express Base Specification Rev.2.0 x1
	Physical dimensions (mm)	169.33(L) x 110.18(H)
	Weight	150g

- *1 Do not input voltages in excess of the maximum input voltage. Similarly, do not input voltage exceeding 1.5 times the range being used, even if less than the maximum input voltage. Inputting too high a voltage may cause a fault.
- *2 The rated precision may not be achieved depending on the cable used.
- *3 The non-linearity error means an error of approximately 0.1% occurs over the maximum range at 0°C and 50°C ambient temperature.
- *4 A 6166[ADC] voltage generator was used for measurements.
- *5 The initial value of the buffer memory is 500K data. Refer to the driver software help for information on how to change the memory size and configurable range. Depending on the OS and PC configuration used, it may not be possible to set the buffer memory to the maximum capacity.

Installation Environment Requirements

Item	AI-1204Z-PE	
Operating ambient temperature	0 - +50°C	
Operating ambient humidity	10 - 90%RH (No condensation)	
Floating dust particles	Not to be excessive	
Corrosive gases	None	
Line-noise resistance	Line noise	AC Line/±2kV Signal Line /±1kV(IEC61000-4-4 Level 3, EN61000-4-4 Level 3)
	Static electricity resistance	Touch /±4kV(IEC61000-4-2 Level 2, EN61000-4-2 Level 2) Air /±8kV(IEC61000-4-2 Level 3, EN61000-4-2 Level 3)
	Vibration resistance	Sweep resistance 10 - 57Hz /semi-amplitude vibration 0.15mm, 57 - 150Hz/2.0G 40minutes each in X, Y, and Z directions (JIS C60068-2-6-compliant, IEC60068-2-6-compliant)
Shock resistance	147m/s ² (15G)/11ms/half-sine shock (JIS C 60068-2-27 -compliant, IEC 60068-2-27 -compliant)	
Standard	VCCI Class A, CE Marking (EMC Directive Class A, RoHS Directive), UKCA	

External Dimensions

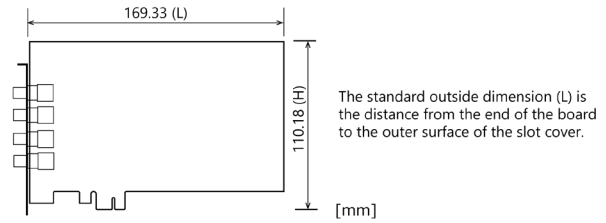

Support Software

You can use CONTEC support software according to your purpose and development environment. For more details on the supported OS, applicable languages, or to download the latest version of software, visit the CONTEC Web site.

Name	Contents	How to get
Driver software API-AIO(WDM)	The API-AIO(WDM) is the Windows version driver software that provides products in the form of Win32 API functions (DLL). Various sample programs such as Visual Basic and Visual C++, etc and diagnostic program useful for checking operation is provided.	Download from the CONTEC website

List of Option

Optional product items are as follows:
Use these items with the main product as necessary.

Product Name	Model type	Description
BNC Cable	BNC-B100	1m
	BNC-B200	2m
	BNC-B300	3m
Conversion Cable (16-Pin to 15-Pin) with Bracket	DT-E3	150mm
Shielded Cable with Connector on both sides for 15-pin D-Type Connector	PCB15PS-1.5P *1*2	1.5m
General Purpose Terminal (M3 x 15P)	FTP-15 *3	

- *1 DT-E3 is required.
- *2 It is required only when FTP-15 is used.
- *3 DT-E3 and PCB15PS-1.5P optional cable is required separately.

* Information about the option products, see the Contec's website.

Connecting to an External Device

Connecting an Interface Connector

To connect an external device to this product, plug the cable from the device into the interface connector (CN1, CN2, CN3, CN4, CN5) shown below.

This product has five interface connectors: the (CN1, CN2, CN3, CN4, BNC connector) for analog inputs and the (CN5, 16-pin pin-header connector) for digital inputs/outputs.

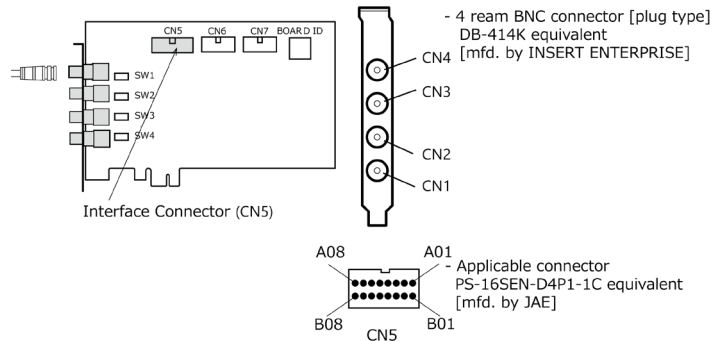

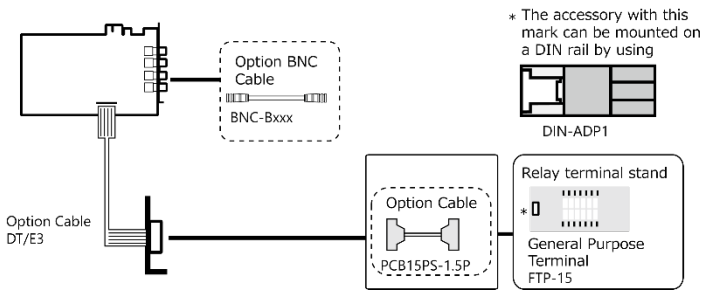

Layout on the Interface Connector(CN1, CN2, CN3, CN4)

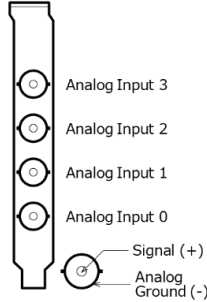

Signal name	Description
Analog Input0 - Analog Input3	Analog input signals. The numbers correspond to channel numbers.
Analog Ground	Analog input signals. The numbers correspond to channel numbers.

CAUTION
If analog and digital ground are shorted together, noise on the digital signals may affect the analog signals. Accordingly, analog and digital ground should be separated.

Layout on the Interface Connector(CN5)

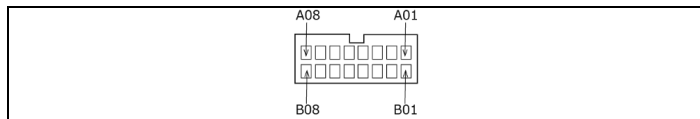

Pin Number	Signal name	Pin Number	Signal name
A01	Digital Output 0	B01	Digital Output 1
A02	Digital Output 2	B02	Digital Output 3
A03	Digital Ground	B03	Digital Input 0
A04	Digital Input 1	B04	Digital Input 2
A05	Digital Input 3	B05	External Start Trigger Input
A06	External Stop Trigger Input	B06	External Sampling Clock Input
A07	AI Status Output	B07	Digital Ground
A08	N.C.	B08	N.C.

Signal name	Description
Digital Input 0 - Digital Input 3	Digital input signal.
Digital Out 0 - Digital Output 3	Digital output signal.
External Start Trigger Input	External trigger input signal for sampling start conditions.
External Stop Trigger Input	External trigger input signal for sampling stop conditions.
External Sampling Clock Input	External sampling clock input signal.
AI Status Output	Output the status signal.
Digital Ground	Digital ground common to each signal.
N.C.	No connection to this pin.

CAUTION
If analog and digital ground are shorted together, noise on the digital signals may affect the analog signals. Accordingly, analog and digital ground should be separated.

Optional cable DT-E3

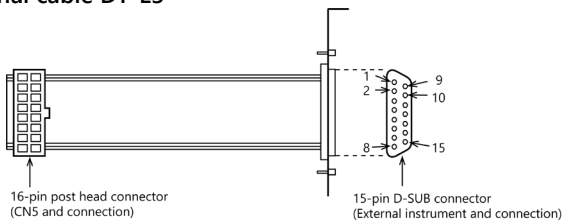

Pin Number	Signal name	Pin Number	Signal name
1	Digital Output 0	9	Digital Output 1
2	Digital Output 2	10	Digital Output 3
3	Digital Ground	11	Digital Input 0
4	Digital Input 1	12	Digital Input 2
5	Digital Input 3	13	External Start Trigger Input
6	External Stop Trigger Input	14	External Sampling Clock Input
7	AI Status Output	15	Digital Ground
8	Reserved		

Connecting Analog Input Signal

Single-ended Input

The following figure shows an example of shielded cable connection. For the CN1 each analog input, connect the core wire to the signal line and connect the shielding to ground.

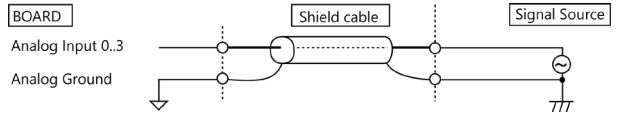

- CAUTION**
- Do not touch the external connector (BNC connector) when the power is on. Otherwise this may malfunction, cause a failure due to static electricity.
 - If the signal source contains over 5MHz signals, the signal may effect the cross-talk noise between channels.
 - If this product and the signal source receive noise or the distance between this product and the signal source is too long, data may not be input properly.
 - The analog signal to be input should not exceed the maximum input voltage (based on this product analog ground). If it exceeds the maximum voltage, this product may be damaged.
 - Input data remains indeterminate when no input pin is connected. The input pin for the channel not connected to the signal source must be connected to the analog ground.
 - An input pin may fail to obtain input data normally when the signal source connected to the pin has high output impedance. If this is the case, change the signal source to one with lower output impedance or insert a high-speed amplifier buffer between the signal source and the analog input board to reduce the effect.

Digital I/O signals and Control signals Connection

This section shows an example of how to connect digital I/O signals and the control signals(external trigger input signals and sampling clock input signal) using flat cable.

User can use an optional cable (DT/E1) or 15-pin D-SUB connector with bracket (DT-E3) and to connect your external devices to CN5. Pulse (width : about 50nsec) synchronized with internal sampling clock is output to the AI Status Output pin. However, if the sampling clock setting is set to the external sampling clock input, level "L" is always output.

AI Status Output pin is an output in positive logic. All the digital I/O signals and control signals are LVTTTL level signals.

Digital Input Connection

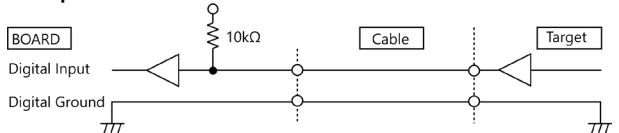

Digital Output Connection

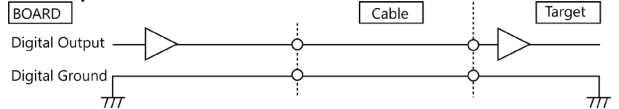

- CAUTION**
- Do not connect any output signal to the analog or digital ground. Do not interconnect outputs. Doing either can cause a malfunction.
 - If connected to each output, a pull-up resistor must be about 10 kΩ to pull up with a 3.3V power source.
 - Each input accepts 5V TTL signals.

Connecting the Sync Connectors (CN6, CN7)

Controlling simultaneous operations between boards or controlling in sync with events is in part depe.

Connection Procedure

Connect the sync signal cable when two or more boards need to operate in sync with one another. Connect CN6 with a smaller ID number to CN7 with a greater ID number with the cable. You should only use the cable that came with the board.

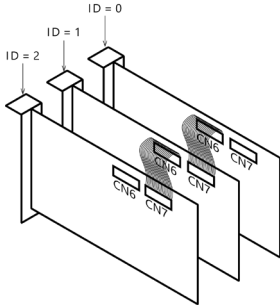

Circuit Block Diagram

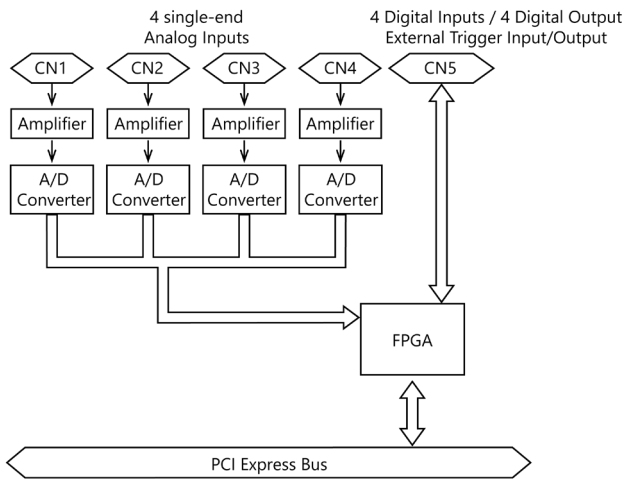

Differences between AI-1204Z-PE and AI-1204Z-PCI

Item	AI-1204Z-PE	AI-1204Z-PCI
For analog (CN1,2,3,4) BNC connector	B-901W1AAN03 equivalent [mfd. By INSERT ENTERPRISE]	DB-414K equivalent [mfd. By INSERT ENTERPRISE]
Bus specification	PCI Express Base Specification Rev.2.0 x1	32bit, 33MHz, Universal key shapes supported
Current consumption (Max.)	5VDC 1600mA, 12V 550mA	5VDC 2500mA